

TECHNICAL SPECIFICATION



**Electronic railway equipment – Train communication network (TCN) –
Part 2-4: TCN application profile**



THIS PUBLICATION IS COPYRIGHT PROTECTED
Copyright © 2017 IEC, Geneva, Switzerland

All rights reserved. Unless otherwise specified, no part of this publication may be reproduced or utilized in any form or by any means, electronic or mechanical, including photocopying and microfilm, without permission in writing from either IEC or IEC's member National Committee in the country of the requester. If you have any questions about IEC copyright or have an enquiry about obtaining additional rights to this publication, please contact the address below or your local IEC member National Committee for further information.

IEC Central Office
3, rue de Varembe
CH-1211 Geneva 20
Switzerland

Tel.: +41 22 919 02 11
Fax: +41 22 919 03 00
info@iec.ch
www.iec.ch

About the IEC

The International Electrotechnical Commission (IEC) is the leading global organization that prepares and publishes International Standards for all electrical, electronic and related technologies.

About IEC publications

The technical content of IEC publications is kept under constant review by the IEC. Please make sure that you have the latest edition, a corrigenda or an amendment might have been published.

IEC Catalogue - webstore.iec.ch/catalogue

The stand-alone application for consulting the entire bibliographical information on IEC International Standards, Technical Specifications, Technical Reports and other documents. Available for PC, Mac OS, Android Tablets and iPad.

IEC publications search - www.iec.ch/searchpub

The advanced search enables to find IEC publications by a variety of criteria (reference number, text, technical committee,...). It also gives information on projects, replaced and withdrawn publications.

IEC Just Published - webstore.iec.ch/justpublished

Stay up to date on all new IEC publications. Just Published details all new publications released. Available online and also once a month by email.

Electropedia - www.electropedia.org

The world's leading online dictionary of electronic and electrical terms containing 20 000 terms and definitions in English and French, with equivalent terms in 16 additional languages. Also known as the International Electrotechnical Vocabulary (IEV) online.

IEC Glossary - std.iec.ch/glossary

65 000 electrotechnical terminology entries in English and French extracted from the Terms and Definitions clause of IEC publications issued since 2002. Some entries have been collected from earlier publications of IEC TC 37, 77, 86 and CISPR.

IEC Customer Service Centre - webstore.iec.ch/csc

If you wish to give us your feedback on this publication or need further assistance, please contact the Customer Service Centre: csc@iec.ch.



TECHNICAL SPECIFICATION



Electronic railway equipment – Train communication network (TCN) – Part 2-4: TCN application profile

INTERNATIONAL
ELECTROTECHNICAL
COMMISSION

ICS 45.060.01

ISBN 978-2-8322-3818-9

Warning! Make sure that you obtained this publication from an authorized distributor.

CONTENTS

FOREWORD.....	6
INTRODUCTION.....	8
1 Scope.....	9
2 Normative references	10
3 Terms, definitions, abbreviated terms, acronyms and conventions.....	11
3.1 Terms and definitions.....	11
3.2 Abbreviated terms and acronyms	13
3.3 Conventions.....	14
3.3.1 Base of numeric values	14
3.3.2 Naming conventions	14
3.3.3 State diagram conventions	15
3.3.4 Elementary data types	15
3.3.5 Derived data types.....	15
4 Distributed train applications	15
4.1 General.....	15
4.2 Function interface for remote control.....	15
4.3 General application architecture.....	16
4.4 Architecture model.....	17
4.5 Assignment of function leader and function follower	18
4.6 Communication flow.....	18
5 Addressing and data format.....	19
5.1 General.....	19
5.2 Function data unit	21
5.2.1 General	21
5.2.2 Function identification.....	22
5.2.3 Channel identification	22
5.2.4 Function instance information	24
5.2.5 Function control information.....	24
5.2.6 Function life sign	25
5.2.7 Function data length	25
5.2.8 Function data set.....	25
5.2.9 Sequence numbers.....	25
6 Transversal functions	28
6.1 General.....	28
6.2 Function train mode	28
6.2.1 Train mode breakdown structure.....	28
6.2.2 Train mode propagation	30
6.2.3 Operation modes	30
6.2.4 Train modes	32
6.2.5 Other train modes.....	40
6.2.6 Parameter train_mode	44
7 Application profiles	48
7.1 Door system application profile	48
7.1.1 Scope	48
7.1.2 Door system breakdown structure.....	49
7.1.3 Door types.....	50

7.1.4	Door application functional breakdown system.....	52
7.1.5	Door application degraded mode	52
7.1.6	Door application special mode	53
7.1.7	Door system interaction	53
7.1.8	Side selective operation.....	60
7.1.9	Door application behaviour	61
Annex A (normative) Profile data definitions.....		78
A.1	Engineering units	78
A.2	Function identification	79
Bibliography.....		88
Figure 1	– IEC TS 61375-2-4 as a link between the functions and the applications	10
Figure 2	– Remote control of a process via the function interface	16
Figure 3	– Architecture of a distributed application.....	16
Figure 4	– Architecture model of a distributed application	17
Figure 5	– Communication flow in the distributed application	19
Figure 6	– Example function instances and their relations	20
Figure 7	– Mapping of function instance relations to communication infrastructure.....	20
Figure 8	– Function data units embedded in TRDP	21
Figure 9	– Structure of function data unit	21
Figure 10	– Structure of function data unit header.....	22
Figure 11	– Illustration of channel relations.....	23
Figure 12	– Example train composition to illustrate sequence numbers.....	26
Figure 13	– Example sequence numbers in counting area train.....	26
Figure 14	– Example sequence numbers in counting area closed train.....	27
Figure 15	– Example sequence numbers in counting area consist.....	27
Figure 16	– Example functional sequence numbers of vehicles in counting area train	28
Figure 17	– Distribution structure for the function train mode	29
Figure 18	– Component structure of function train mode	29
Figure 19	– Example operation modes state diagram	32
Figure 20	– Example train modes state diagram.....	40
Figure 21	– Parameter train_mode.....	44
Figure 22	– Distribution structure of the door application	49
Figure 23	– Architecture of the door system.....	49
Figure 24	– Door types	50
Figure 25	– Communication path for entry doors	51
Figure 26	– Communication path for interconnecting doors	51
Figure 27	– Communication path for entry doors of sleeping cars	51
Figure 28	– Communication path for interconnecting doors of sleeping cars	52
Figure 29	– Communication flow of triggers for entry doors.....	54
Figure 30	– Communication flow of triggers for neighbouring interconnecting doors.....	57
Figure 31	– Neighbouring consist DCUs for neighbouring interconnecting doors	58
Figure 32	– Communication flow of triggers for control of interconnecting doors of sleeping cars	59

Figure 33 – Side selective parameterization of triggers	61
Figure 34 – State machine structure of DCU and consist DCU	62
Figure 35 – DCU state diagram for entry doors	64
Figure 36 – DCU state diagram for neighbouring interconnecting doors	67
Figure 37 – DCU state diagram for interconnecting doors of sleeping cars	68
Figure 38 – Consist DCU state diagram for entry doors.....	69
Figure 39 – Consist DCU state diagram for neighbouring interconnecting doors.....	71
Figure 40 – Consist DCU state diagram for interconnecting doors of sleeping cars	73
Figure 41 – Train DCU state diagram.....	75
Table 1 – Channel groups.....	23
Table 2 – Control information.....	25
Table 3 – OperationModes.....	45
Table 4 – TrainModes	46
Table 5 – OtherTrainMode	48
Table 6 – Operation scenarios	52
Table 7 – Door application degraded mode.....	53
Table 8 – Door application special mode.....	53
Table 9 – Triggers between TCMS and train DCU.....	55
Table 10 – Local triggers for the train DCU	55
Table 11 – Triggers between train DCU and consist DCU	55
Table 12 – Triggers between consist DCU and DCU for entry doors.....	56
Table 13 – Local triggers for the DCU	56
Table 14 – Triggers between DCU and door.....	56
Table 15 – Triggers between consist DCU and consist DCU for neighbouring interconnecting doors	57
Table 16 – Triggers between consist DCU and DCU for neighbouring interconnecting doors	58
Table 17 – Triggers between consist DCU and consist DCU for interconnecting doors of sleeping cars	59
Table 18 – Triggers between consist DCU and DCU for interconnecting doors of sleeping cars	60
Table 19 – DCU state definitions.....	63
Table 20 – DCU triggers for entry doors.....	65
Table 21 – DCU operations for entry doors	66
Table 22 – DCU state definitions for neighbouring interconnecting doors	66
Table 23 – DCU state definitions for interconnecting doors of sleeping cars.....	67
Table 24 – Consist DCU state definitions for entry doors	68
Table 25 – Additional consist DCU state definitions for entry doors of sleeping cars	69
Table 26 – Consist DCU Triggers for entry doors	70
Table 27 – Consist DCU Conditions for entry doors	70
Table 28 – Consist DCU Operations for entry doors	71
Table 29 – Consist DCU state definitions for neighbouring interconnecting doors	71
Table 30 – Consist DCU Triggers for neighbouring interconnecting doors	72

Table 31 – Consist DCU Operations for neighbouring interconnecting doors 72

Table 32 – Consist DCU state definitions for interconnecting doors of sleeping cars 72

Table 33 – Consist DCU Triggers for interconnecting doors of sleeping cars 73

Table 34 – Consist DCU Operations for interconnecting doors of sleeping cars 73

Table 35 – Train DCU state definitions 74

Table 36 – Train DCU triggers 76

Table 37 – Train DCU conditions 76

Table 38 – Train DCU operations 77

Table A.1 – Physical quantities (e.g. 16 bit integer type) 78

Table A.2 – Physical quantities (other data types) 79

Table A.3 – List of function identifiers 80

Table A.4 – List of sub-function identifiers and instance info 83

INTERNATIONAL ELECTROTECHNICAL COMMISSION

**ELECTRONIC RAILWAY EQUIPMENT –
TRAIN COMMUNICATION NETWORK (TCN) –****Part 2-4: TCN application profile**

FOREWORD

- 1) The International Electrotechnical Commission (IEC) is a worldwide organization for standardization comprising all national electrotechnical committees (IEC National Committees). The object of IEC is to promote international co-operation on all questions concerning standardization in the electrical and electronic fields. To this end and in addition to other activities, IEC publishes International Standards, Technical Specifications, Technical Reports, Publicly Available Specifications (PAS) and Guides (hereafter referred to as “IEC Publication(s)”). Their preparation is entrusted to technical committees; any IEC National Committee interested in the subject dealt with may participate in this preparatory work. International, governmental and non-governmental organizations liaising with the IEC also participate in this preparation. IEC collaborates closely with the International Organization for Standardization (ISO) in accordance with conditions determined by agreement between the two organizations.
- 2) The formal decisions or agreements of IEC on technical matters express, as nearly as possible, an international consensus of opinion on the relevant subjects since each technical committee has representation from all interested IEC National Committees.
- 3) IEC Publications have the form of recommendations for international use and are accepted by IEC National Committees in that sense. While all reasonable efforts are made to ensure that the technical content of IEC Publications is accurate, IEC cannot be held responsible for the way in which they are used or for any misinterpretation by any end user.
- 4) In order to promote international uniformity, IEC National Committees undertake to apply IEC Publications transparently to the maximum extent possible in their national and regional publications. Any divergence between any IEC Publication and the corresponding national or regional publication shall be clearly indicated in the latter.
- 5) IEC itself does not provide any attestation of conformity. Independent certification bodies provide conformity assessment services and, in some areas, access to IEC marks of conformity. IEC is not responsible for any services carried out by independent certification bodies.
- 6) All users should ensure that they have the latest edition of this publication.
- 7) No liability shall attach to IEC or its directors, employees, servants or agents including individual experts and members of its technical committees and IEC National Committees for any personal injury, property damage or other damage of any nature whatsoever, whether direct or indirect, or for costs (including legal fees) and expenses arising out of the publication, use of, or reliance upon, this IEC Publication or any other IEC Publications.
- 8) Attention is drawn to the Normative references cited in this publication. Use of the referenced publications is indispensable for the correct application of this publication.
- 9) Attention is drawn to the possibility that some of the elements of this IEC Publication may be the subject of patent rights. IEC shall not be held responsible for identifying any or all such patent rights.

The main task of IEC technical committees is to prepare International Standards. In exceptional circumstances, a technical committee may propose the publication of a technical specification when

- the required support cannot be obtained for the publication of an International Standard, despite repeated efforts, or
- the subject is still under technical development or where, for any other reason, there is the future but no immediate possibility of an agreement on an International Standard.

Technical specifications are subject to review within three years of publication to decide whether they can be transformed into International Standards.

IEC TS 61375-2-4, which is a technical specification, has been prepared by IEC technical committee 9: Electrical equipment and systems for railways, in collaboration with UIC.

The text of this technical specification is based on the following documents:

Enquiry draft	Report on voting
9/2093/DTS	9/2150A/RVC

Full information on the voting for the approval of this technical specification can be found in the report on voting indicated in the above table.

This publication has been drafted in accordance with the ISO/IEC Directives, Part 2.

A list of all parts in the IEC 61375 series, published under the general title *Electronic railway equipment – Train communication network (TCN)*, can be found on the IEC website.

The committee has decided that the contents of this publication will remain unchanged until the stability date indicated on the IEC website under "<http://webstore.iec.ch>" in the data related to the specific publication. At this date, the publication will be

- transformed into an International standard,
- reconfirmed,
- withdrawn,
- replaced by a revised edition, or
- amended.

A bilingual version of this publication may be issued at a later date.

IMPORTANT – The 'colour inside' logo on the cover page of this publication indicates that it contains colours which are considered to be useful for the correct understanding of its contents. Users should therefore print this document using a colour printer.

INTRODUCTION

IEC TS 61375-2-4 defines the application profiles of the Train Communication Network in order to achieve communication between software applications throughout consist networks defined in IEC 61375-1 and the train backbone defined in IEC 61375-2-5.

This part of IEC 61375 defines the requirements for the applications communicating via the data transmission equipment of the consists throughout the consist networks and the train backbones.

The purpose of this part of IEC 61375 is to:

- fully document the communication requirements for all train applications, align them and set them out in standard form,
- provide guidelines for the technical solution of communication between software applications residing on the same or on different consists, which are part of a train, and which are connected to the consist networks and the train backbones in scope,
- define train applications for certain functionalities, which are in scope of this part of IEC 61375.

ELECTRONIC RAILWAY EQUIPMENT – TRAIN COMMUNICATION NETWORK (TCN) –

Part 2-4: TCN application profile

1 Scope

This part of IEC 61375 applies to the applications in trains, i.e. it covers the application profile for functions belonging to the Train Control and Monitoring System (TCMS). The application profile is based on the TCN communication system for the data communication between consists of the said trains. This document provides for a data interface with parameters and addressing of TCMS functions based on the communication profile laid out in IEC 61375-2-3.

This document is applicable in rolling stock requiring interoperable coupling and uncoupling. This part of IEC 61375 may be additionally applicable to closed trains and multiple unit trains when so agreed between purchaser and supplier.

The applicability of this part of IEC 61375 to the train communication network technologies as defined allows for interoperability of individual consists within trains.

The data communication systems inside consists are not covered by this document and are given only as example solutions to cope with the said TCN. In any case, proof of compatibility between a proposed train backbone and a proposed consist network will have to be brought by the supplier.

Special backup functions, which are used in cases when the train backbone is in a degraded condition are not in the scope of this document.

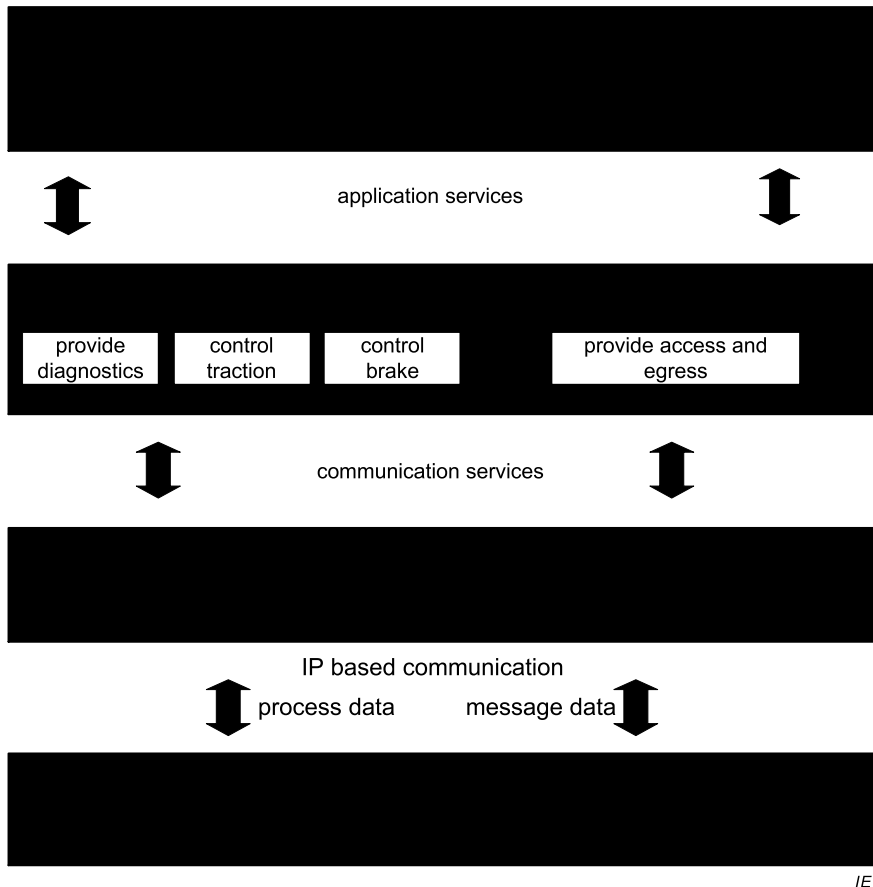

Figure 1 – IEC TS 61375-2-4 as a link between the functions and the applications

As illustrated in Figure 1 the purpose of this part of IEC 61375 is to create a general model that describes in a functional way the remote control of TCMS functions like “provide access and egress”. This document makes direct reference to IEC 61375-2-3, which covers data transmission on the Ethernet train backbone (ETB) and specifies the functions between the consists concerned (e.g. locomotives, multiple units and driving trailers) including the rules to set up the necessary data telegrams for transmission and process.

This document specifies the application profiles covering the train functions to:

- a) provide access and egress;
- b) control traction;
- c) control brake;
- d) provide diagnostics.

NOTE Functions b) to d) will be covered in a future revision of this document.

2 Normative references

The following documents are referred to in the text in such a way that some or all of their content constitutes requirements of this document. For dated references, only the edition cited applies. For undated references, the latest edition of the referenced document (including any amendments) applies.

IEC 61375-1, *Electronic railway equipment – Train communication network (TCN) – Part 1: General architecture*

IEC 61375-2-1, *Electronic railway equipment – Train communication network (TCN) – Part 2-1: Wire Train Bus (WTB)*

IEC 61375-2-3, *Electronic railway equipment – Train communication network (TCN) – Part 2-3: TCN communication profile*

3 Terms, definitions, abbreviated terms, acronyms and conventions

3.1 Terms and definitions

For the purposes of this document, the terms and definitions given in IEC 61375-1 and the following apply.

ISO and IEC maintain terminological databases for use in standardization at the following addresses:

- IEC Electropedia: available at <http://www.electropedia.org/>
- ISO Online browsing platform: available at <http://www.iso.org/obp>

3.1.1

all doors of consist CLOSED

each single door of the consist is closed

Note 1 to entry: This state is side selective.

3.1.2

all doors of consist LOCKED

each single door of the consist is locked

Note 1 to entry: This state is side selective.

3.1.3

all doors of train CLOSED

all doors of each consist are closed

Note 1 to entry: This state is side selective.

3.1.4

all doors of train LOCKED

all doors of each consist are locked

Note 1 to entry: This state is side selective.

3.1.5

application profile

defined standardized set of services or functions offered to the application processes for information exchange with specified data formats and data processing

3.1.6

CLOSE

action to juxtapose the door to its frame, to obstruct an entrance or opening

3.1.7

consist FAILURE

the consist is defined in failure state when the consist DCU control function or communication is in failure

Note 1 to entry: Failure detection may be realized by self-diagnostic of the consist DCU or by function supervision of consist DCU by the train DCU (e.g. process data sink time supervision).

3.1.8

door ATTENDED

single door which remains active and open after the crew manipulator associated with it (e.g. square key) has remotely commanded all the other doors of the train to close

3.1.9

door CLOSED

the door is defined closed when the door is adjacent to its frame and the mechanical locking device is not in effect, making possible the mechanical opening of the door itself

Note 1 to entry: In this condition it is possible to move the door electrically or pneumatically.

3.1.10

door OUT OF ORDER

when at least one of the following conditions applies:

- a) the link to the remote control is failing;
- b) the door cannot be controlled locally

3.1.11

door ISOLATED

when it is closed and mechanically locked by means of the appropriate mechanical closure device

Note 1 to entry: In this condition the door is permanently closed and locked and it cannot be moved in any way.

Note 2 to entry: In this condition the internal emergency handle and the outside one have no effect on the opening of the door.

3.1.12

ISOLATE door

to close and mechanically lock the door and leave the door unable to execute any operation command

Note 1 to entry: ISOLATE door uses mechanical methods in case of door malfunction. For example the door isolation device is located on the door leaf, it is accessible from inside and /or outside via a square (or triangular) key lock.

3.1.13

door LOCKED

the door is defined locked when the physical door is adjacent to its frame and the mechanical locking device is in effect, making it impossible to open the door mechanically

Note 1 to entry: In this condition it is impossible to move the door physically.

3.1.14

door OPENED

the door is defined as opened when it is not adjacent to its frame and the entrance is not blocked

Note 1 to entry: In this condition it is ready to accept a closing command.

3.1.15

driving trailer

vehicle with a driving cab at least at one end of the vehicle from which the traction and braking functions of a train can be controlled

3.1.16

functional address

unique identification for a function

3.1.17**leading vehicle**

vehicle, which is elected by a communication service of IEC 61375-2-3 and which controls the movements of the train

3.1.18**locomotive**

motor vehicle, not forming part of a train-unit and not carrying a payload, intended to move other vehicles

[SOURCE: IEC 60050-811:2017, 811-02-06]

3.1.19**OPEN**

action to move the physical door and create an entrance

3.1.20**passenger coach**

passenger carrying vehicle without its own propulsion system

3.1.21**shoegear**

train equipment to transfer electric current from the third rail

Note 1 to entry: It is usually mounted on bogies.

3.1.22**traction unit**

vehicle with its own power equipment

3.1.23**vehicle**

single item of rolling stock

Note 1 to entry: Examples of a single item of rolling stock include a locomotive, a coach and a wagon.

[SOURCE: IEC 60050-811:2017, 811-02-02]

3.2 Abbreviated terms and acronyms

ASC	Automatic Speed Control
ASN.1	Abstract Syntax Notation 1
DAC	Driver Activity Control
DB	Deutsche Bahn (German Railways)
DCU	Door Control Unit
DDU	Driver Display Unit
DMU	Diesel Multiple Unit
ED	End Device
EMU	Electric Multiple Unit
ENUM	Enumeration
ETB	Ethernet Train Backbone
ETCS	European Train Control System
FI	Function Interface
HMI	Human Machine Interface

HV	High Voltage
HVAC	Heating Ventilation and Air Conditioning
ID	Identification
IP	Internet Protocol
LV	Low Voltage
MD	Message Data
OSI	Open System Interconnection NOTE A universal communication model is defined in ISO/IEC 7498.
PD	Process Data
PDU	Protocol Data Unit
SNCF	Société Nationale des Chemins de fer Français (French National Railways)
TBN	Train Backbone Node
TCMS	Train Control and Monitoring System
TCN	Train Communication Network
TRDP	Train Real time Data Protocol
TTDB	Train Topology Data Base
UDP	User Datagram Protocol
UIC	Union Internationale des Chemins de Fer (International Union of Railways)
UML	Unified Modelling Language
WC	Water Closet
WSP	Wheel Slide Protection

3.3 Conventions

3.3.1 Base of numeric values

This document uses a decimal representation for all numeric values unless otherwise noted.

Analog and fractional values include a comma.

EXAMPLE The voltage is 20,0 V.

Binary and hexadecimal values are represented using the ASN.1 (ISO/IEC 8824) convention.

EXAMPLE Decimal 20 coded on 8 bits = '0001 0100'B = '14'H.

3.3.2 Naming conventions

Keywords are written with a capital letter at the beginning.

If the keyword name is composed of multiple words, the different words are united with a space and each word begins with a capital letter.

EXAMPLES "Train Backbone", "Consist", "Consist Network".

Parameters are written with a capital letter at the beginning.

If the parameter name is composed of different words, the different parts of the name are united without a space and each word begins with a capital letter.

EXAMPLE "NumberOfConsists".

3.3.3 State diagram conventions

State diagrams are according to the notation of UML state machines.

3.3.4 Elementary data types

Elementary data types are used as defined in IEC 61375-2-1.

3.3.5 Derived data types

Derived data types consist of elementary data types, like for instance enumerations and structures. Derived data types are implementation dependent; they are mainly user- or manufacturer specific data types.

The enumerated data type declarations (ENUM) constrain the value of any data element of that type to one of the values given.

4 Distributed train applications

4.1 General

The technology of the various traction units within the various railway operators can be very different, considering, for example, the setting up of the traction power (contact breakers, switch gear, converters) and its control (relay logic, analogue and digital electronic equipment, microprocessors). A similar situation exists e.g. for doors providing external access to the train for the passengers.

4.2 Function interface for remote control

Because of the existing technical differences, there are also large differences in the input and output signals of the control equipment. Therefore it is not possible, in most cases, to use the signals transmitted over the train backbone to directly control the equipment or to obtain these signals directly from the control equipment. Consequently the remote function control process needs to communicate via a standardized function interface, which ensures the access to the remote door function process

Figure 2 shows as an example a common situation, when operating a train: One of the train's driver cabs on either end is the activated cab in the leading vehicle. In this cab the train driver is controlling the train's movement by actuating e.g. the traction lever. The command, generated by moving the traction lever on the driver's desk, sampled, and received by one traction function (called function control) and propagated throughout the train via the train backbone to all other traction functions via the comm proxy controlling locally the specific traction subsystems. These processes, which are controlling the traction subsystems in each consist or vehicle are called function process in Figure 2.

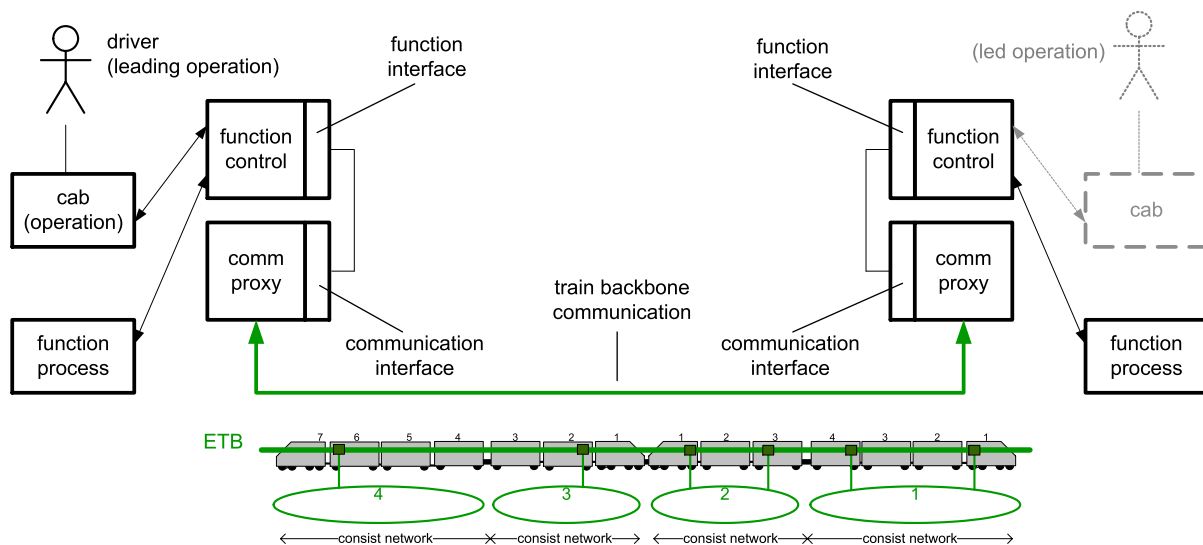

IEC

Figure 2 – Remote control of a process via the function interface

In Figure 2 the scenario is shown for the example of two driving cabs at each end of the train, one cab in leading operation and the other cab in unattended and led operation. For this remote control of functions, a set of signals, a so-called function interface, defines the necessary set of data for a function to fulfil its characteristic action in the intended manner. The way to transmit this set of signals via the ETB is defined as the communication interface for the train backbone communication defined in IEC 61375-2-3. These transmitted signals need to be translated in each consist in order to work with the actual control equipment of the related subsystems. Figure 2 shows this process, whereas the train backbone communication is the synonym for the data connections via the train backbone and the individual consist networks.

Like the presented remote traction control function in Figure 2 above, there are additional remote functions in a train, e.g. controlling doors, HVAC, exterior lighting, brakes. Thus a communication link is established between the application function processes according to rules laid out in this document.

4.3 General application architecture

The network architecture according to IEC 61375-1 defines the framework and constraints for distributed applications in a train. Figure 3 illustrates this architecture with a generic application.

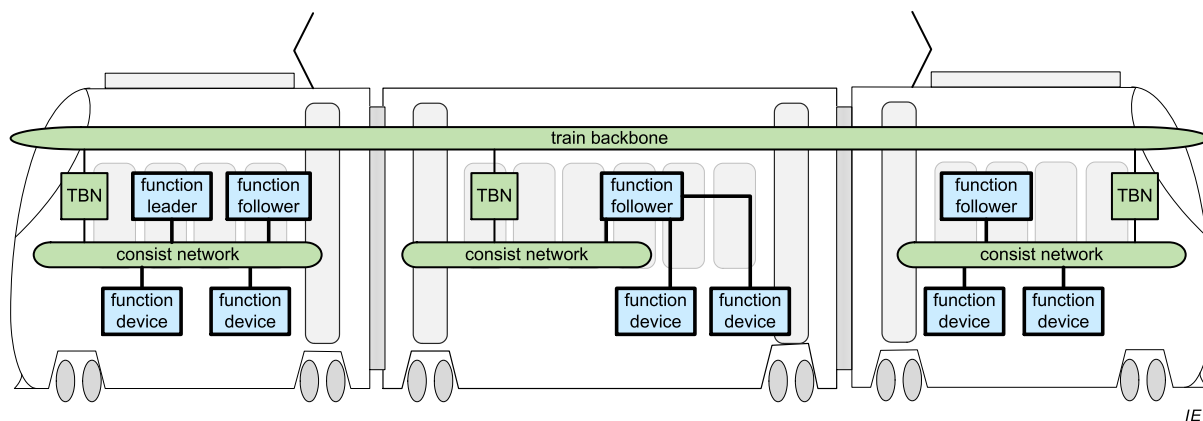

IEC

Figure 3 – Architecture of a distributed application

A train is composed by consists. Each consist contains a consist network, which is connected via a train backbone node (TBN) to the train backbone, which provides the communication

infrastructure for the train wide communication. Train backbone, consist network, TBN are the basic components of the train communication network (TCN) according to IEC 61375 series.

The generic function is composed of:

- a) a function leader which is responsible to control the function by stimulation of the function followers (commands) and to receive the reactions from the function followers (status);
- b) one or more function follower(s), at most one per consist network, which is responsible to receive the commands from the function leader and to stimulate the function devices. The received reactions from the function devices are cumulated by the function follower and provided as function status of the consist to the function leader;
- c) one or more function device(s), which are receiving the commands from the function follower, execute the function operations and report the results to the function follower.

These parts of the application are distributed over the consists of the train. Different parts of the application in different consists can communicate only via the TCN.

For interoperability of consists only the communication between function leader and function follower is relevant. The interaction between function follower and function device is provided as information for better understanding of the behaviour of the application.

This technical specification does not require the consist network as communication infrastructure between function follower and function device. There may be any connection, e.g. wired by simple electric lines.

4.4 Architecture model

Figure 4 shows a graphical representation of the distributed application, which is used to model the communication flow (see 4.6).

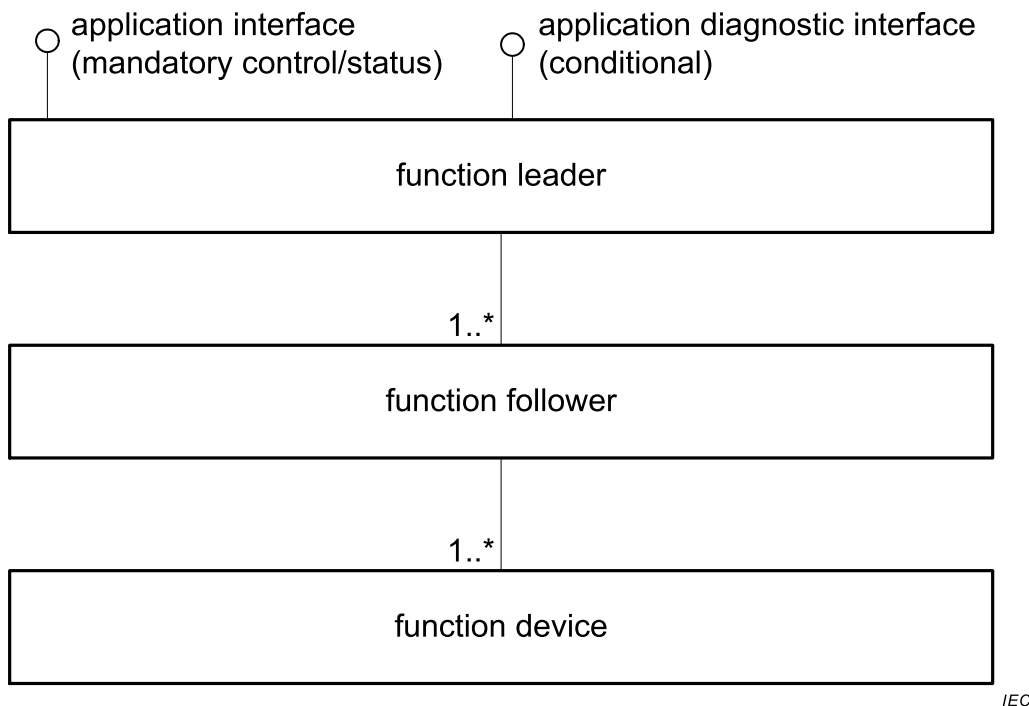

Figure 4 – Architecture model of a distributed application

The parts of the application need to cooperate to fulfil the requested function. Consequently these parts are source and sink of triggers, which stimulate this cooperation.

There shall be one Function Leader, which provides interfaces for the TCMS:

- a) an application interface to execute the control the operations and to get the status of the application;
- b) conditional an application diagnostic interface for additional information about the status of the application, if there is such information.

The function leader shall communicate with the function follower as agent for the consist. The function leader shall not assume a specific implementation of the parts of the application inside a consist.

NOTE There is no direct communication between the function leader and the function devices.

The function follower shall be responsible to control the application operation inside a consist. For interoperability the function follower shall not expose implementation details of the consist to the function leader.

4.5 Assignment of function leader and function follower

In order to communicate between e.g. a push button in the driver's cab, which calls "release all left doors" and the function "release door" in each consist, the following architecture is chosen (see 4.4): The function door control is split within a train into one train function leader and one or more function followers which are responsible to control the individual doors in each consist. The function leader is responsible for the communication with the subordinate function followers.

The roles function leader and function follower are implemented in function carriers inside the consists. Normally the function leader is located in the leading consist. If a train contains two consists at both ends, which can get leading, then there are two function carriers, which can host the function leader.

For each function a mechanism is needed, to assign the function leader and the function followers. This mechanism can be based on the dynamic properties (e.g. Leading) in the TTDB. This mechanism is defined in the description of the specific application profile.

4.6 Communication flow

Figure 5 illustrates this communication flow in the distributed application. Only the communication between function leader and function follower is in the scope of this document.

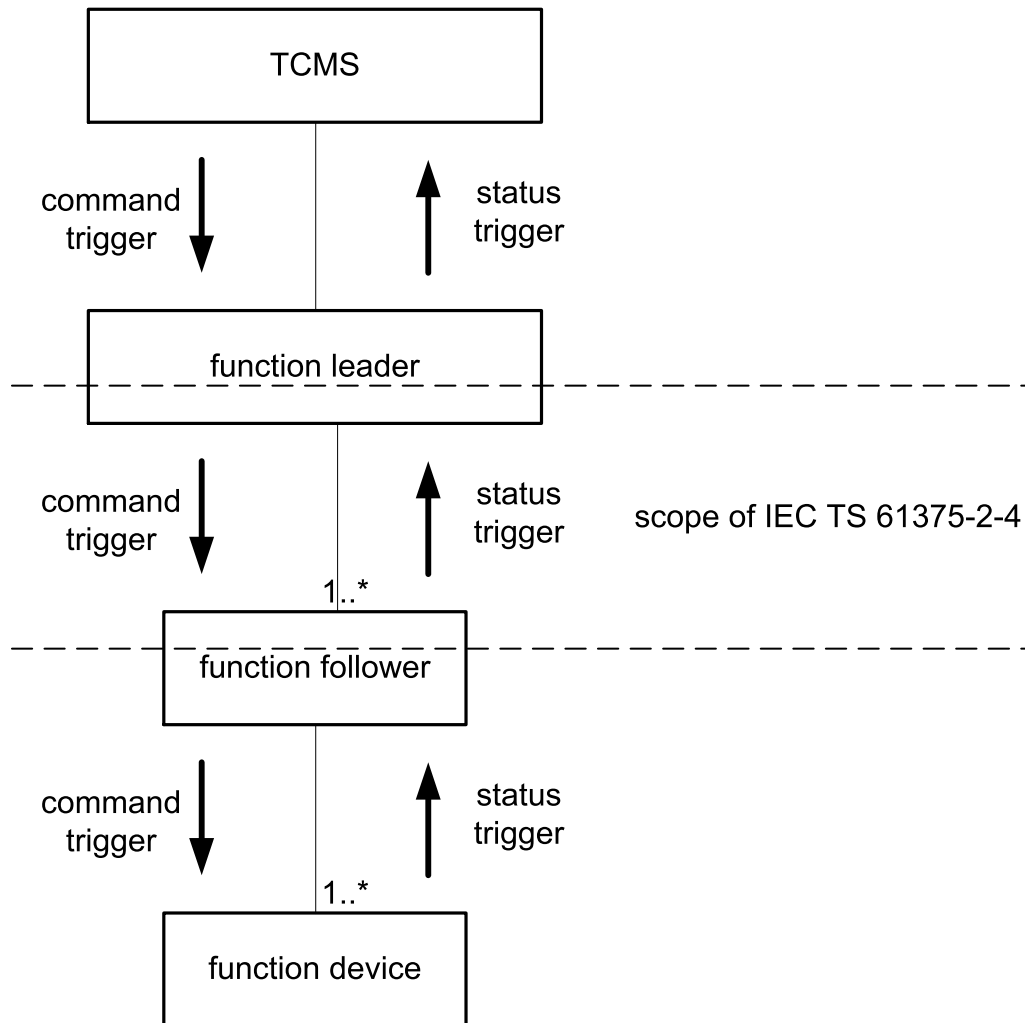

IEC

Figure 5 – Communication flow in the distributed application

To execute an application operation, the TCMS triggers the function leader with the appropriate command.

The function leader triggers all its function followers in the corresponding consists (networks) by sending the appropriate telegram.

Each function follower triggers the function device of the application by the appropriate command to perform the requested operation and receives the reaction (status) from the function device.

The function follower receives and cumulates the status from all its function devices and reports this cumulated status to the function leader.

The function leader receives and cumulates the status from all its function followers and reports this cumulated status to the TCMS.

5 Addressing and data format

5.1 General

According to 4.3, a function is distributed across the train. From an application point of view the function is treated as a unity, and the details of the communication are hidden. Figure 6

illustrates the principle of the parts (function instances) of a function group and the relations between the function instances. A function instance can be, e.g. a function leader or a function follower. The function instance relations begin and end at the function interfaces (FI) of the function instances.

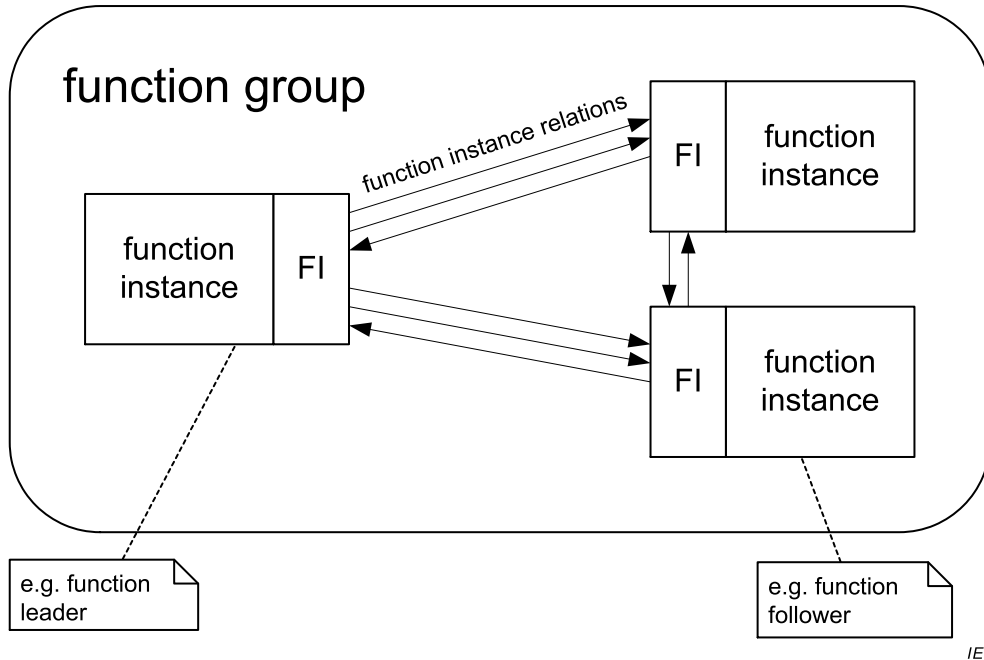

Figure 6 – Example function instances and their relations

Figure 7 shows the mapping of the function instance relations to the communication infrastructure. The function instance relations are supported by logical function channels, which hide the implementation of the data transfer.

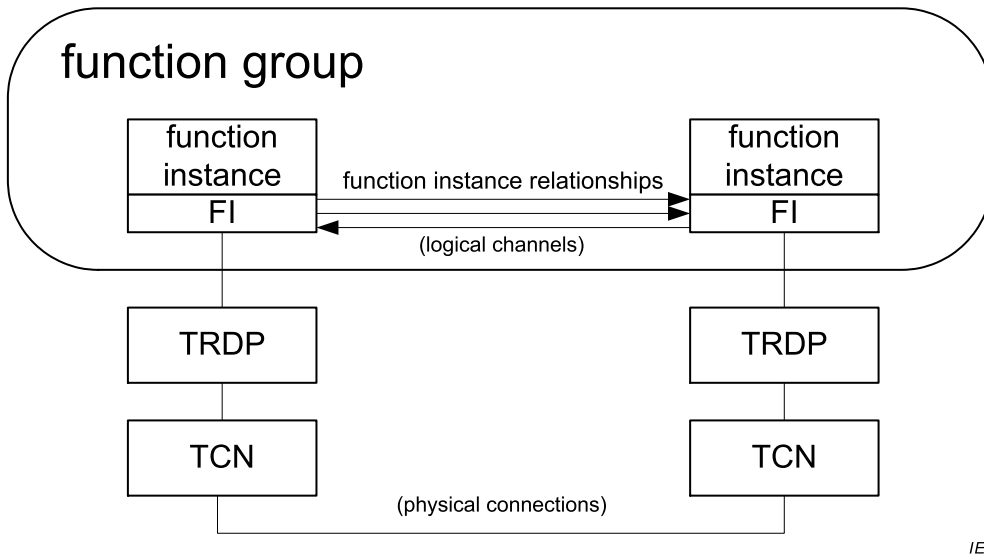

Figure 7 – Mapping of function instance relations to communication infrastructure

The channels permit the modelling of fine grained function instance relationships. To unambiguously identify a function channel, it is necessary to specify:

- a) the function group itself, (e.g. door control);
- b) the kind of function instance relation (e.g. function leader communicates with function follower);

- c) a specific function instance or a group of function instances (e.g. function instance in second vehicle or all function followers).

To locate the function instances in the train the static and dynamic properties stored in the TTDB are used. Since a train may be composed of closed trains or of consists with vehicles, it is possible to specify a function instance by its position in the train, closed train or consist. The needed information is stored in the TTDB also.

The function instances exchange their data via the function channels in function data units. Since the amount of data per function data unit is generally small compared with the overhead of TRDP, multiple function data units shall be packed in one TRDP telegram.

Figure 8 illustrates that the transport service provider protocol data unit (TSP-PDU) contains the process data in a train realtime data protocol data unit (TRDPDU), according to IEC 61375-2-3. This TRDPDU contains one or more function data units (FDU) in order to provide an efficient communication link between the function instances. One FDU contains the function specific signals for one function channel. Each header controls the handling according to the level of protocol and is precedes each of the data units.

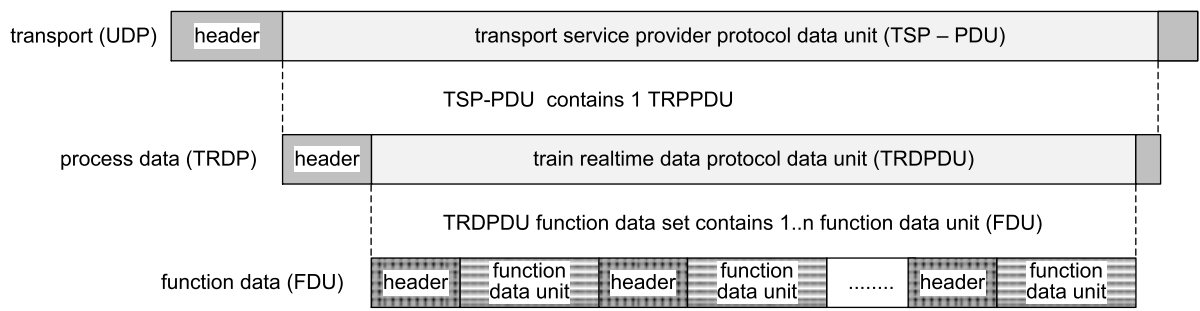

IEC

Figure 8 – Function data units embedded in TRDP

5.2 Function data unit

5.2.1 General

The function instances exchange their data via the function channels. Each function channel shall be associated with one function data unit. Figure 9 illustrates the structure of a function data unit.

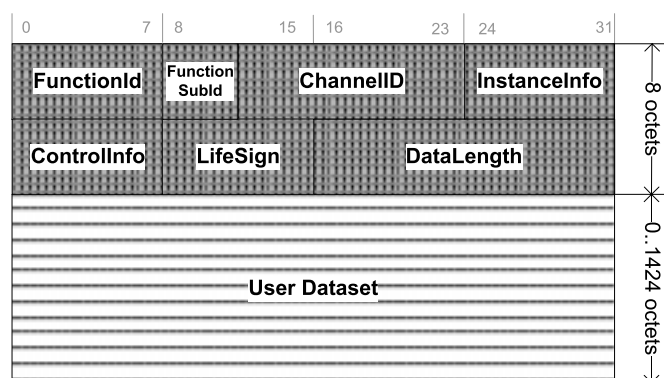

IEC

Figure 9 – Structure of function data unit

Figure 10 illustrates the structure of a function data unit header.

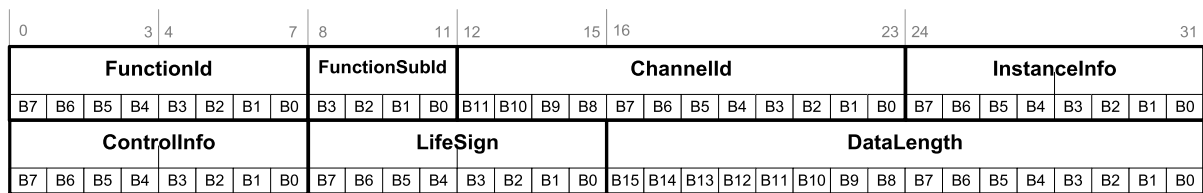

IEC

Figure 10 – Structure of function data unit header

```

STRUCT_FUNCTION_DATA_HEADER ::= STRUCT
{
    FunctionId           UNSIGNED8           -- function group identification
    FunctionSubId       UNSIGNED4           -- function sub-group identification
    ChannelId           UNSIGNED12          -- channel specification
    InstanceInfo        UNSIGNED8           -- additional function instance
                                                addressing info
    ControlInfo         BITSET8             -- control bits
    LifeSign            UNSIGNED8           -- sequence counter used as life sign
    DataLength          UNSIGNED16          -- length of data block
}

STRUCT_FUNCTION_DATA ::= STRUCT
{
    Header              STRUCT_FUNCTION_DATA_HEADER -- header information
    DataSet             UNSIGNED8[Header.DataLength] -- function data block
}
    
```

For specification of structures `STRUCT_FUNCTION_DATA` and `STRUCT_FUNCTION_DATA_HEADER` refer to 5.2.2 to 5.2.8.

5.2.2 Function identification

The function identification `FunctionId` shall identify the function group according to Table A.3 in Clause A.2. The function identification `FunctionSubId` shall identify the function sub-group within a function group according to Table A.4 in Clause A.2.

Example 1: `FunctionId` '92'H refers to External doors.

Example 2: `FunctionId` '22'H, `FunctionSubId` '2'H, `InstanceInfo` 1 refers to function instance class "AC_outer" (main circuit breaker AC exterior section) in sub-function "Energy main circuit breaker" in function group "Power supply".

5.2.3 Channel identification

For one function / sub-function identification one or more channels may exist. One channel shall carry all signals of the same pair of sender and receiver.

The combination of function / sub-function identification and channel identification `ChannelId` shall uniquely identify a channel between function instances.

NOTE 1 The channel implicitly defines sender and receiver.

The channels shall support the following channel relations, see Figure 11:

- a) point-to-point;
- b) one-to-many, with same data for all receivers;
- c) one-to-many, with specific data for each receiver;
- d) many-to-one, with specific data from each sender.

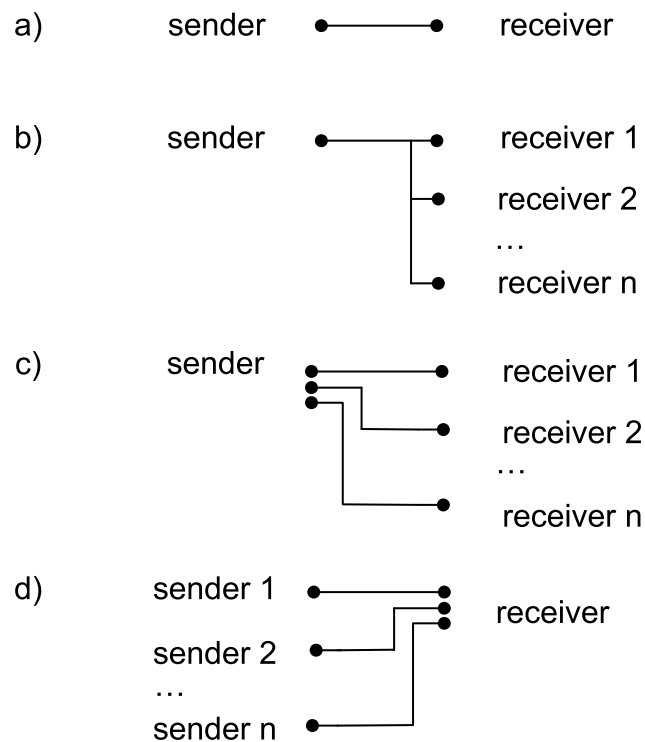

IEC

Figure 11 – Illustration of channel relations

To allocate the channels to the intended pairs of sender and receiver, they shall be assigned to channel groups according to Table 1:

Table 1 – Channel groups

Channel group	Sender level	Receiver level	Communication relation
A	train	closed train	function leader on train level to function follower on closed train level
B	closed train	vehicle	function leader on closed train level to function follower on vehicle level
C	train	vehicle	function leader on train level to function follower on vehicle level
D	train	train	function leaders on train level (e.g. function leadership negotiation)
E	closed train	closed train	function leaders on closed train level (e.g. function leadership negotiation)
F	closed train	closed train	from peer to peer in whole train
G	vehicle	vehicle	from peer to peer restricted to closed train boundaries
H	vehicle	vehicle	from peer to peer in whole train

NOTE Peer may be either a function leader or function follower.

For the channel groups A, B and C, the function leader resides on the superordinated level.

The impact of function communication depends on the used channel group. For example, in a multiple unit train, communication within channel group A will affect the whole train, but communication within channel group B will affect only one closed train of the multiple unit train.

Channel groups D and E are provided for function leader candidate to function leader candidate communication, e.g. negotiation of a function leader (see also 4.5).

Channel groups F, G and H are provided for peer-to-peer communication between function leaders on closed train level or between function followers on a vehicle level.

NOTE 2 The channel identification defines the hierarchical levels (train, closed train, vehicle) of sender and receiver. For example, the channel from sender exterior door function leader on train level to all receiver function follower on vehicle level.

The channels are unidirectional. The channel for the reverse communication direction shall be assigned to the same channel group.

Furthermore the channels shall be divided in two channel interoperability groups:

- e) interoperable channels;
- f) private channels.

The interoperable channels are used by the communication of applications defined by this document. These channels shall not be used for other purposes as assigned in this document.

The private channels can be used for communication of project or operator specific applications or for applications which have no need for interoperability, for example applications inside a closed train. These channels will never be assigned to the group of interoperable channels in the future.

5.2.4 Function instance information

The instance information InstanceInfo shall be interpreted depending on the control bit UserDatasetContent:

- a) UserDatasetContent = "Structure"
 - 1..127: the number of the function instance in the related counting area (see 5.2.9.1), counted according to the rules in 5.2.9.
 - 0: refers to all instances in the counting area.

The instance number identifies the affected instance either as sender or as receiver, depending on the direction of the associated channel.

- b) UserDatasetContent = "Array"
 - Number of used array elements

5.2.5 Function control information

The function control information ControlInfo is a bit set and shall be used according to Table 2.

Table 2 – Control information

Bit	Name	Value	Description
B0	UserDatasetContent	0 "Structure"	The data set contains a single data structure, field InstanceInfo is interpreted for a single data structure.
		1 "Array"	The data set contains an array of data structures, field InstanceInfo is interpreted for a data array.
B1	reserved	0	reserved for future use
		1	reserved for future use
B2	reserved	0	reserved for future use
		1	reserved for future use
B3	reserved	0	reserved for future use
		1	reserved for future use
B4	reserved	0	reserved for future use
		1	reserved for future use
B5	reserved	0	reserved for future use
		1	reserved for future use
B6	reserved	0	reserved for future use
		1	reserved for future use
B7	reserved	0	reserved for future use
		1	reserved for future use

5.2.6 Function life sign

The function life sign LifeSign is a counter, which shall be incremented each time, when the data set DataSet is forwarded to the communication protocol stack. The increment shall be done modulo 256.

5.2.7 Function data length

The function data length DataLength shall contain the length of the function data set (see 5.2.8). The length shall be counted in number of octets.

5.2.8 Function data set

The function data set contains the application data. The length of the function data set shall be a multiple of 2 (16-bit aligned).

The data structure "Structure" (control bit UserDatasetContent = 0) shall be used for point-to-point relations.

The data structure "Array" (control bit UserDatasetContent = 1) shall be used for one-to-many relations and for many-to-one relations. The number of receivers and senders resp. shall be determined by the information in the TTDB. Specific elements in the array shall be addressed by the field InstanceInfo.

5.2.9 Sequence numbers

5.2.9.1 General

Figure 12 illustrates an example train composition. In this example the train is composed by three closed trains, which are composed each by one or more consists, which are composed by one or more vehicles. The ETB reference direction is assumed from right to left.

NOTE 1 For definition of the reference directions, refer to IEC 61375-2-3.

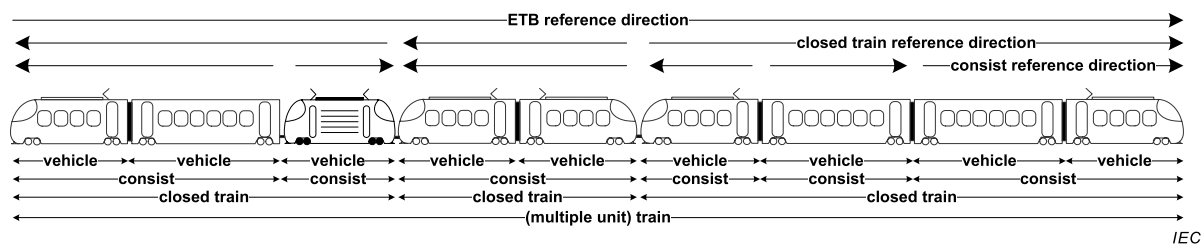

Figure 12 – Example train composition to illustrate sequence numbers

The train is structured by four hierarchical levels:

- a) (multiple unit) train;
- b) closed train;
- c) consist;
- d) vehicle.

Countable entities for sequence numbers are vehicles, consists and closed trains.

NOTE 2 Counting on the level of the complete train is pointless, because there is only one train.

Each countable entity can be counted in a counting area. Counting areas are on the level of consist, level of closed train and level of train.

NOTE 3 Counting on the level of vehicle is pointless, because there is only one vehicle.

Two kinds of sequence numbers for countable entities are defined:

- e) topological sequence numbers, base on the physical composition of the train;
- f) functional sequence numbers, based on static properties of vehicle, consist and closed train.

5.2.9.2 Topological sequence numbers

Topological sequence numbers depend only on the physical composition of the train and the superordinated counting area.

In the counting area train:

- a) the vehicles shall be counted ascending starting with 1 from the first vehicle in the train;
- b) the consists shall be counted ascending starting with 1 from the first consist in the train;
- c) the closed trains shall be counted ascending starting with 1 from the first closed in the train.

Figure 13 illustrates the sequence numbers for the entities vehicle, consist and closed train in the counting area train according to the example composition of Figure 12.

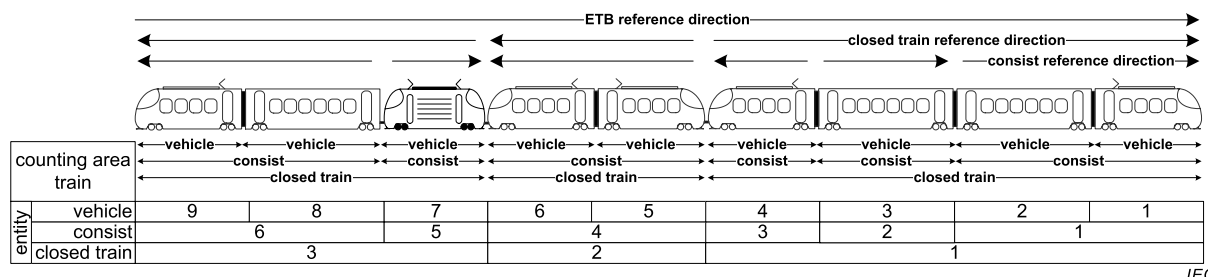
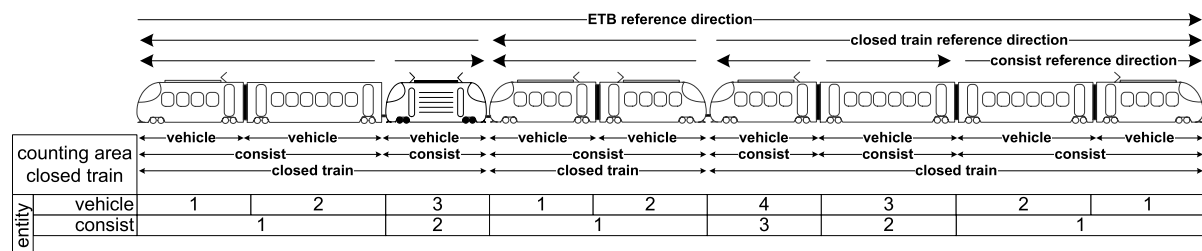

Figure 13 – Example sequence numbers in counting area train

In the counting area closed train:

- d) the vehicles shall be counted ascending starting with 1 from the first vehicle in their closed train;
- e) the consists shall be counted ascending starting with 1 from the first consist in their closed train.

Figure 14 illustrates the sequence numbers for the entities vehicle and consist in the counting area closed train according to the example composition of Figure 12.



IEC

Figure 14 – Example sequence numbers in counting area closed train

In the counting area consist:

- f) the vehicles shall be counted ascending starting with 1 from the first vehicle in their consist.

Figure 15 illustrates the sequence numbers for the entities vehicle in the counting area consist according to the example composition of Figure 12.

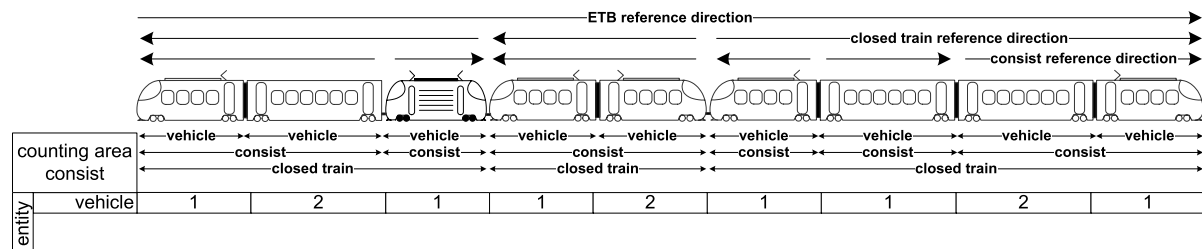

IEC

Figure 15 – Example sequence numbers in counting area consist

5.2.9.3 Functional sequence numbers

Functional sequence numbers depend on the composition of the train and the superordinated counting area and the static properties.

Vehicles shall be counted ascending starting with 1 from the first vehicle with the related vehicle property. A vehicle shall be counted only if it has the related vehicle property.

Consists shall be counted ascending starting with 1 from the first consist with the related consist property. A consist shall be counted only if it has the related consist property.

Closed trains shall be counted ascending starting with 1 from the first closed train with the related closed train property. A closed train shall be counted only if it has the related closed train property.

The counting areas shall be respected as defined in 5.2.9.2.

Figure 16 illustrates the sequence numbers for the entities vehicle in the counting area train depending on the static vehicle properties "has traction", "has traction control" and "has entry doors" as example.

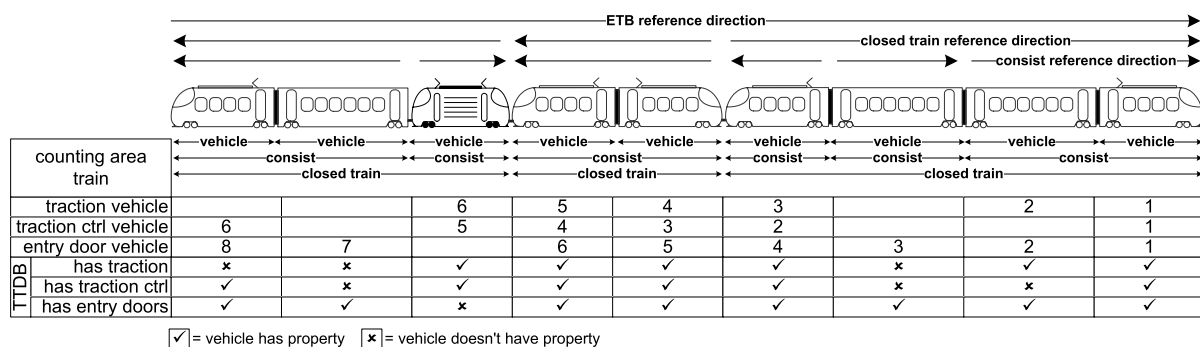

IEC

Figure 16 – Example functional sequence numbers of vehicles in counting area train

For the counting entities vehicle, consist and closed train and the counting areas closed train and consist in conjunction with the appropriate static properties the same method as in Figure 16 applies.

5.2.9.4 Absolute and relative sequence numbers

The definitions in 5.2.9.1 to 5.2.9.3 specify absolute sequence numbers. Additionally it shall be possible to apply relative sequence numbers, starting from the own counted entity with the value zero. In direction of the counting area, the sequence number shall be decremented by one, in opposite direction of the counting area, the sequence number shall be incremented by one.

6 Transversal functions

6.1 General

Clause 6 is applicable to all consists (traction units, driving trailers, multiple units, and passenger coaches) that are equipped with a train backbone in accordance with IEC 61375-1.

Other kinds of rolling stock, e.g. EMUs, DMUs (see 3.2) and high-speed trains may comply with this clause in order to develop the remote control of applications based on this technical specification and to achieve interoperability.

Clause 6 does not standardize neither the implementation of the functions in the individual vehicles, nor the design and arrangement of the control equipment, but only the application interface among the vehicles via the communication connection using the train backbone.

6.2 Function train mode

6.2.1 Train mode breakdown structure

According to the general application architecture (see 4.1), Figure 17 illustrates the distribution of the components for function train mode.

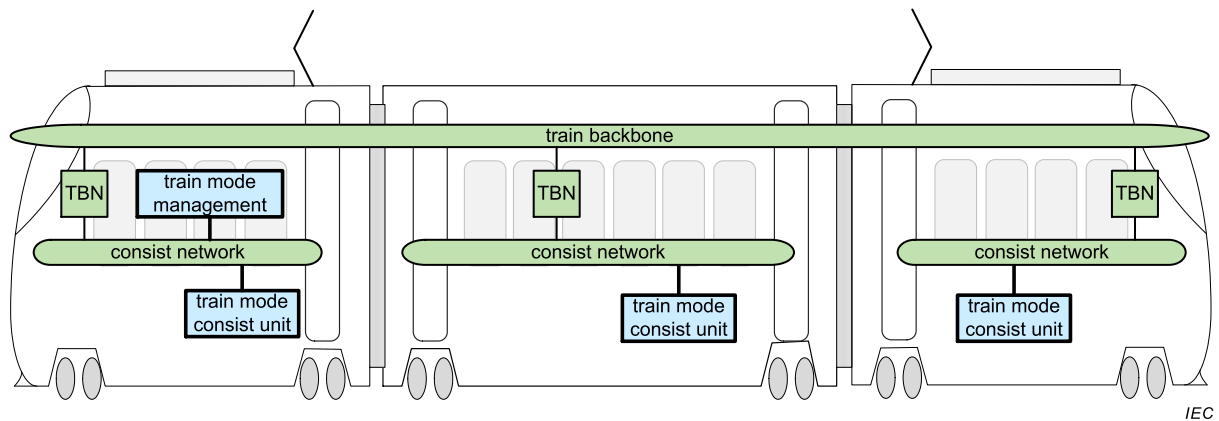

Figure 17 – Distribution structure for the function train mode

This technical specification does not require a specific consist network. Either a consist network according to IEC 61375 or any other network may be deployed, because the consist internal implementation is not in the scope of this document.

Figure 18 illustrates the component structure of the function train mode with its interfaces to the TCMS.

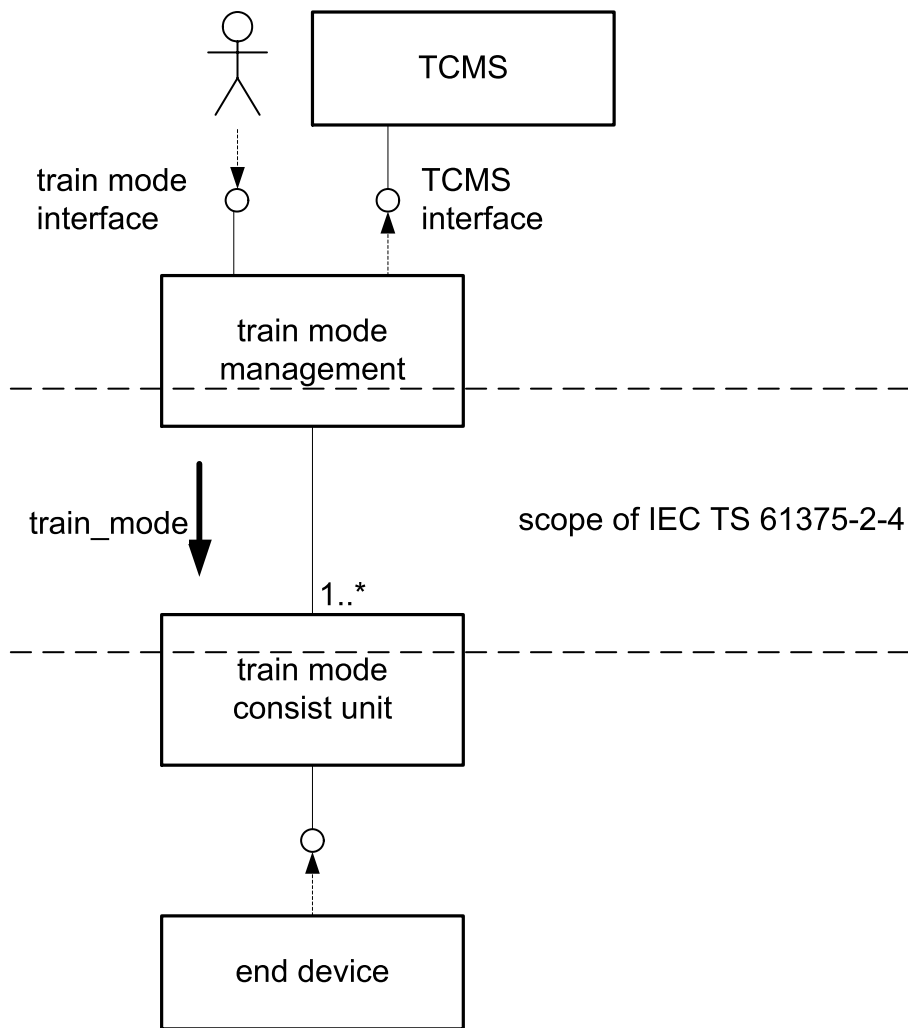

Figure 18 – Component structure of function train mode

The function train mode provides an interface at the component train mode management to set information about the state of the train. The definition of this interface is not in the scope of this document.

The function train mode uses the interface of TCMS to get additional information about the actual state of the train. The definition of this interface is not in the scope of this document.

The train mode management sends the parameter train_mode to the train mode consist units in each consist.

The train mode consist unit provides an interface to offer the parameter train_mode to the end devices. The definition of this interface is not in the scope of this document.

6.2.2 Train mode propagation

The component train mode management sends the parameter train_mode (see 6.2.4) to all train mode consist units as process data when it changes.

The train mode consist units assume a value of none for the parameter train_mode (see 6.2.4) before the first receive of this process data.

6.2.3 Operation modes

6.2.3.1 General

The description of the operation modes is informative, the normative requirements regarding the applications will be defined in the corresponding application profile.

6.2.3.2 Normal operation mode

6.2.3.2.1 General

The mode NormalOperationMode applies to the operation of train or locomotive in normal conditions.

6.2.3.2.2 Normal operation sub-modes project specific modes

Up to three different project specific modes are provided.

6.2.3.3 Maintenance mode

6.2.3.3.1 General

The mode MaintenanceMode applies when the train is in maintenance and under test in the depot in standstill or running.

In this mode the download of approved configurations of software and parameters is allowed.

Incoming diagnostics events are marked.

Maintenance information and extended diagnostics information are available on DDU.

6.2.3.3.2 Maintenance sub-mode service

In the maintenance sub-mode Service simple checks at the HMI are allowed.

6.2.3.3.3 Maintenance sub-mode inspection

In the maintenance sub-mode Inspection checks and test-procedures via the web interface are allowed.

6.2.3.3.4 Maintenance sub-mode restoration

In the maintenance sub-mode Restoration extended checks and test-procedures are allowed, protection functions can be disabled.

6.2.3.3.5 Maintenance sub-mode improvement

In the Maintenance sub-mode Improvement the train is subject to improvements.

6.2.3.3.6 Maintenance sub-modes project specific modes

Up to three different project specific modes are provided.

6.2.3.4 Commissioning mode

6.2.3.4.1 General

The mode CommissioningMode applies when the train is in commissioning and under test in the depot/test facility in standstill or running.

All functionalities from the maintenance mode are available.

Download of non-approved configurations of software and parameters is also allowed.

To force signals for commissioning purposes additional protection (e.g. by password or an ID card has to be foreseen) is requested.

No further restrictions.

6.2.3.4.2 Commissioning sub-modes

No sub-modes are defined.

6.2.3.5 Operation mode interface

The train mode management provides an interface to set the triggers

- a) RequestCommissioningMode
- b) RequestMaintenanceMode

This interface ensures that not both requests are set at the same time. The definition of this interface is not in the scope of this document.

6.2.3.6 Operation mode state transitions

Figure 19 shows an example state diagram of the Operation Modes:

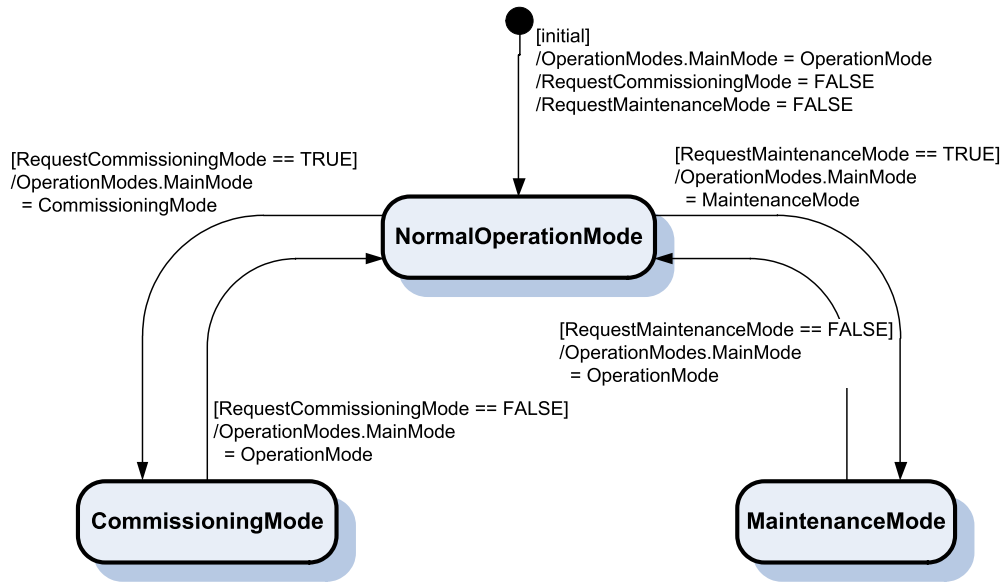

IEC

Figure 19 – Example operation modes state diagram

6.2.4 Train modes

6.2.4.1 General

The description of the train modes is informative, the normative requirements regarding the applications will be defined in the corresponding application profile. The mentioned “ID card reader” in the subsequent subclauses is only an example for an identification device. No specific implementation is required by this document.

6.2.4.2 Battery protection mode

6.2.4.2.1 General

The mode BatteryProtectionMode applies when the train is in standstill or towed by another mechanically and pneumatically coupled train or loco.

Battery protection has switched off all electrical consumers after giving time for a controlled shutdown of those.

Only battery protection device itself remains powered.

Brake pipe status is unchanged (and depends on previous mode).

Emergency brake is available.

Train horn is available.

For resetting this protection mode, the battery main switch is set from "off" to "on" position.

6.2.4.2.2 Battery protection sub-modes

No sub-modes are defined.

6.2.4.3 Shutdown mode

6.2.4.3.1 General

The mode ShutdownMode applies when the train is in standstill or is being pulled.

Battery main switch is off and no battery deep discharge has been signalled.

6.2.4.3.2 Shutdown sub-mode parking mode

The ShutdownMode sub-mode ParkingMode applies to the train when it is in standstill with the battery main switch switched off.

All electrical consumers are switched off. Only those connected directly to the battery are supplied with power as indicated by the following list:

- a) battery deep discharge protection is active;
- b) interior light is available (if on, will be switched off automatically after 15 min);
- c) WSP is available (in stand-by);
- d) train backbone node is in sleep mode (and ready for switching on the battery);
- e) functionality to switch on the battery by radio remote connection is available (if such a functionality has been built in);
- f) brake mode selection is available;
- g) emergency brake is available;
- h) train horn is available.

Brake pipe is emptied and then isolated and automatic application of the parking brake. Unintentional feeding of the brake pipe by leakages of connections to main pipe or reservoirs is prevented.

Automatic parking brake (local) is compensating decrease of brake cylinder pressure (only controlled by reservoir).

ParkingMode is possible for at least 150 h without reaching the self protection mode.

6.2.4.3.3 Shutdown sub-mode pulled mode

The ShutdownMode sub-mode PulledMode applies to the train when it is pulled "as a wagon", i.e. towed by another mechanically and pneumatically coupled train or loco.

The following list shows the differences against the parking mode:

- a) WSP is active;
- b) brake mode selector is operational;
- c) brake isolation and release device is operational.

The ShutdownMode sub-mode PulledMode is possible for at least 24 h without reaching the self protection configuration. The emergency brake is available as well as the train horn.

6.2.4.4 Switched on mode

6.2.4.4.1 General

The mode SwitchedOnMode applies when the train is in standstill and it is the first step after start-up.

Battery main switch is closed ("on"). All low voltage consumers are supplied.

Main reservoir is connected to the air consumers (operable, if pressure is present).

All driver displays are available for information only, except for some control functions – e.g. train radio.

The preconditions for activating the pantograph or shoegear are fulfilled:

- a) main circuit breaker is open ("off");
- b) pantograph or shoegear is not available (due to aux pressure generated for the pantograph or shoegear);
- c) no cab is activated as master;
- d) leading vehicle is undefined;
- e) ID card reader is available;
- f) head light control is available;
- g) cab and timetable light control is available;
- h) instrument light control is available.

Following functions are locally available:

- i) train horn;
- j) emergency brake;
- k) application of direct brake;
- l) switching off main circuit breaker;
- m) lower pantograph or detach shoegear;
- n) communication with other driver cab via train radio;

Traction and brake control are not available.

If there is no battery charging for 45 min, then the battery main switch will be opened (this will cause a transition to the ShutdownMode)

6.2.4.4.2 Switched on sub-mode battery power supply

In the SwitchedOnMode sub-mode BatteryPowerSupply, LV consumers, connected to battery, are supplied.

Up to two different project specific sub-modes are provided.

6.2.4.4.3 Switched on sub-mode depot power supply

In the SwitchedOnMode sub-mode DepotPowerSupply, depot power supply provides power to additional LV consumers; restrictions to performance apply.

Depot power supply has to be switched off to raise pantograph or attach shoegear and to connect to HV.

6.2.4.4.4 Switched on sub-mode catenary power supply

In the SwitchedOnMode sub-mode CatenaryPowerSupply, connection to HV power supply is provided implying configuration of voltage systems, energy transformation and distribution.

6.2.4.4.5 Switched on sub-mode battery switch off initiated

In the SwitchedOnMode sub-mode BatterySwitchOffInitiated, the main circuit breaker opens soon, all devices prepare for power loss, e.g. persist data and shutdown.

6.2.4.4.6 Switched on sub-mode power system change

In the SwitchedOnMode sub-mode PowerSystemChange, the train reconfigures the voltage system.

6.2.4.5 In service mode

6.2.4.5.1 General

The mode InServiceMode applies when the train is in standstill, low voltage is supplied and one driver cab is activated.

In service mode one cab has been activated as a train-wide master cab and the following conditions apply:

- a) battery main switch is closed ("on"). All low voltage consumers are supplied;
- b) main reservoir is connected to the air consumers (operable, if pressure is present);
- c) pantograph or shoegear is available;
- d) main circuit breaker is available;
- e) direct brake is available;
- f) TCMS ensures that only one cab is activated as master.

After coupling or uncoupling detected by TCMS: The TCMS monitors continuously the train composition in order to be able to detect any modification.

After successful inauguration (no master conflict, degraded devices have been identified) the driver is requested to confirm the train composition in the driver display.

In case of a master conflict (= no or more than 1 master), a traction inhibition is commanded train-wide, the train inauguration configuration cannot be left successfully.

After this driver confirmation following the successful train inauguration, the train composition applies. The duration of the train inauguration is expected to be shorter than 2 min.

The TCMS shows in every non-master cab that a master cab exists on the train.

After successful train inauguration:

- g) leading vehicle is defined;
- h) driver displays are available for control in the active cab;
- i) train preparation and disposal can be executed in this mode from the master cab.

After successful train preparation, the following conditions apply:

- j) all functions are available from the master cab, except traction, electrical braking and brake pipe control;
- k) master cab is able to control the travel direction; travel direction has not been chosen;
- l) other cabs than the master cab can only issue "local" commands in the vehicle and not train-wide commands, interaction with functions controlled from the master cab is interlocked by TCMS.

TCMS will ignore all train-wide commands from these other cabs and the driver in the master cab will be informed about this situation by the driver display.

For ETCS, all modes (except for sleeping mode) are available in the leading vehicle, ETCS sleeping mode is applied to other vehicles.

A command for a shutdown while HV supply is "on" has to organize the shutdown of all HV consumers, switch off the main circuit breaker, lower the pantograph or detach the shoe gear, organize the shutdown of all LV consumers and set the battery main switch to "off".

6.2.4.5.2 In service sub-mode battery power supply

For the description of InServiceMode sub-mode BatteryPowerSupply see 6.2.4.4.2.

6.2.4.5.3 In service sub-mode depot power supply

For the description of InServiceMode sub-mode DepotPowerSupply see 6.2.4.4.3.

Up to three different project specific sub-modes are provided.

6.2.4.5.4 In service sub-mode catenary power supply

For the description of InServiceMode sub-mode CatenaryPowerSupply see 6.2.4.4.4.

6.2.4.5.5 In service sub-mode battery switch off initiated

For the description of InServiceMode sub-mode BatterySwitchOffInitiated see 6.2.4.4.5.

6.2.4.5.6 In service sub-mode power system change

For the description of InServiceMode sub-mode PowerSystemChange see 6.2.4.4.6.

6.2.4.6 Energy saving mode

6.2.4.6.1 General

The mode EnergySavingMode applies when the train is in standstill; low voltage is supplied, train power line supplied (HV or external), no driver cab is activated, the energy consumption is in saving mode.

EnergySavingMode means parking with energy-supply and preparation ability; all the following conditions apply:

- a) all functions from the In service mode (see 6.2.4.5) can be made available again, e.g. by only re-inserting the driver's ID card;
- b) battery main switch is closed ("on"). All low voltage consumers are supplied;
- c) main reservoir is connected to the air consumers (operable, if pressure is present);
- d) ETCS retains the last train data input, unless driver action;
- e) HVAC and other consumers are in energy saving mode;
- f) HVAC and consumers can be reactivated as well as tests can be started by timer, remote signal or frost protection;
- g) parking brake is applied;
- h) leading vehicle remains defined, train remains in prepared status.

If there is no battery charging for 45 min an organized shutdown will be executed; this will cause a transition to the shutdown mode.

6.2.4.6.2 In EnergySavingMode sub-mode Battery Power Supply

For the description of EnergySavingMode sub-mode BatteryPowerSupply see 6.2.4.4.2.

6.2.4.6.3 In EnergySavingMode sub-mode Depot Power Supply

For the description of EnergySavingMode sub-mode DepotPowerSupply see 6.2.4.4.3.

6.2.4.6.4 In EnergySavingMode sub-mode CatenaryPowerSupply

For the description of EnergySavingMode sub-mode CatenaryPowerSupply see 6.2.4.4.4.

6.2.4.6.5 In EnergySavingMode sub-mode Battery Switch Off Initiated

For the description of EnergySavingMode sub-mode BatterySwitchOffInitiated see 6.2.4.4.5.

6.2.4.7 Service Retention mode**6.2.4.7.1 General**

The mode ServiceRetentionMode applies to the train when it is in standstill, low voltage is supplied, HV is supplied, no driver cab activated. This mode will be entered, if the driver changes cabs.

All functions from the In service mode (see 6.2.4.5) can be made available again, e.g. by only re-inserting the driver's ID card.

In this condition:

- a) parking brake is applied.
- b) all cabs are available to be activated by the driver;
- c) TCMS retains the last train configuration.

ETCS retains the last train data input, unless driver action for a new input and if the train composition has not changed.

Leading vehicle remains defined in this mode, until this mode will be left by changing the master cab or by an train inauguration.

6.2.4.7.2 Service retention sub-modes

No sub-modes are defined.

6.2.4.8 Driving mode**6.2.4.8.1 General**

The mode DrivingMode applies in standstill or running; low voltage is supplied, one driver cab is activated and operation mode requested.

In driving mode every function is available, i.e. normal operation mode, coupling active mode, washing mode and transition mode are specific sub-modes of the driving mode.

The following conditions apply:

- a) battery main switch is "on". All low voltage consumers are supplied and the relevant reservoirs are connected to the air consumers (operable, if pressure is present);
- b) pantograph or shoe gear is available;

- c) main circuit breaker available;
- d) direct brake is available;
- e) holding brake is available;
- f) direction of travel choice is available;
- g) choice of operation sub-mode (normal, coupling active, washing, etc.) is possible;
- h) traction, dynamic braking and brake pipe control available;
- i) brake pipe control can be locally switched off (e.g. if there is no train backbone connection between independent traction units, like in pushing (helper) operation);
- j) driver activity control (DAC) is active;
- k) leading vehicle is defined;
- l) displays are available for control in active cab driver;
- m) train-wide control can be executed in this mode from the master cab.

TCMS ensures that only one cab is activated as master.

TCMS does not accept another ID card in parallel. While running, TCMS ignores any further ID-card. At stand-still TCMS triggers a train-wide traction-inhibition.

Other cabs than the master cab can only issue "local" commands in the vehicle and not train-wide commands, interaction with functions controlled from the master cab is interlocked by TCMS.

For ETCS, all modes (except for Sleeping Mode) are available in the leading vehicle, ETCS Sleeping Mode is applied to other vehicles.

6.2.4.8.2 DrivingMode sub-mode power system change

For the description of DrivingMode sub-mode PowerSystemChange see 6.2.4.4.6.

6.2.4.8.3 DrivingMode sub-mode Normal mode

In DrivingMode sub-mode NormalMode the train is in normal driving mode.

6.2.4.8.4 DrivingMode sub-mode Transition mode

In DrivingMode sub-mode TransitionMode the train passes a neutral section.

6.2.4.9 Towing mode

6.2.4.9.1 General

The mode TowingMode applies when the train is not supplied with main power and cannot move by itself, but is pulled "as a wagon", i.e. towed by another mechanically and pneumatically coupled train or loco.

The battery power supply is switched on and auxiliary power may be available.

6.2.4.9.2 Towing sub-modes

No sub-modes are defined.

6.2.4.10 Emergency mode

6.2.4.10.1 General

The mode EmergencyMode disables all electrical locks for braking and driving functions. Indirect brake is available via driver's brake valve.

The mode EmergencyMode is a special operation mode, which allows the driving despite of severe degradation of the TCMS in one or more vehicles or failure of the train communication network (e.g. in case of fire) for a specified duration (under generally bypassing of protection functions). The goal is to prevent that the train will stop and remain at a critical infrastructure location (e.g. bridge or tunnel). The train driver takes the responsibility for EmergencyMode.

6.2.4.10.2 Emergency sub-modes

No sub-modes are defined.

6.2.4.11 Train modes interface

The train mode management provides an interface to set the triggers:

- a) RequestBatteryProtectionMode
- b) RequestShutdownMode
- c) RequestSwitchedOnMode
- d) RequestInServiceMode
- e) RequestEnergySavingMode
- f) RequestServiceRetentionMode
- g) RequestDrivingMode
- h) RequestTowingMode
- i) RequestEmergencyMode

This interface ensures that only one request is set at any time. The definition of this interface is not in the scope of this document.

6.2.4.12 Train modes state transitions

Figure 20 shows an example state diagram of the train modes:

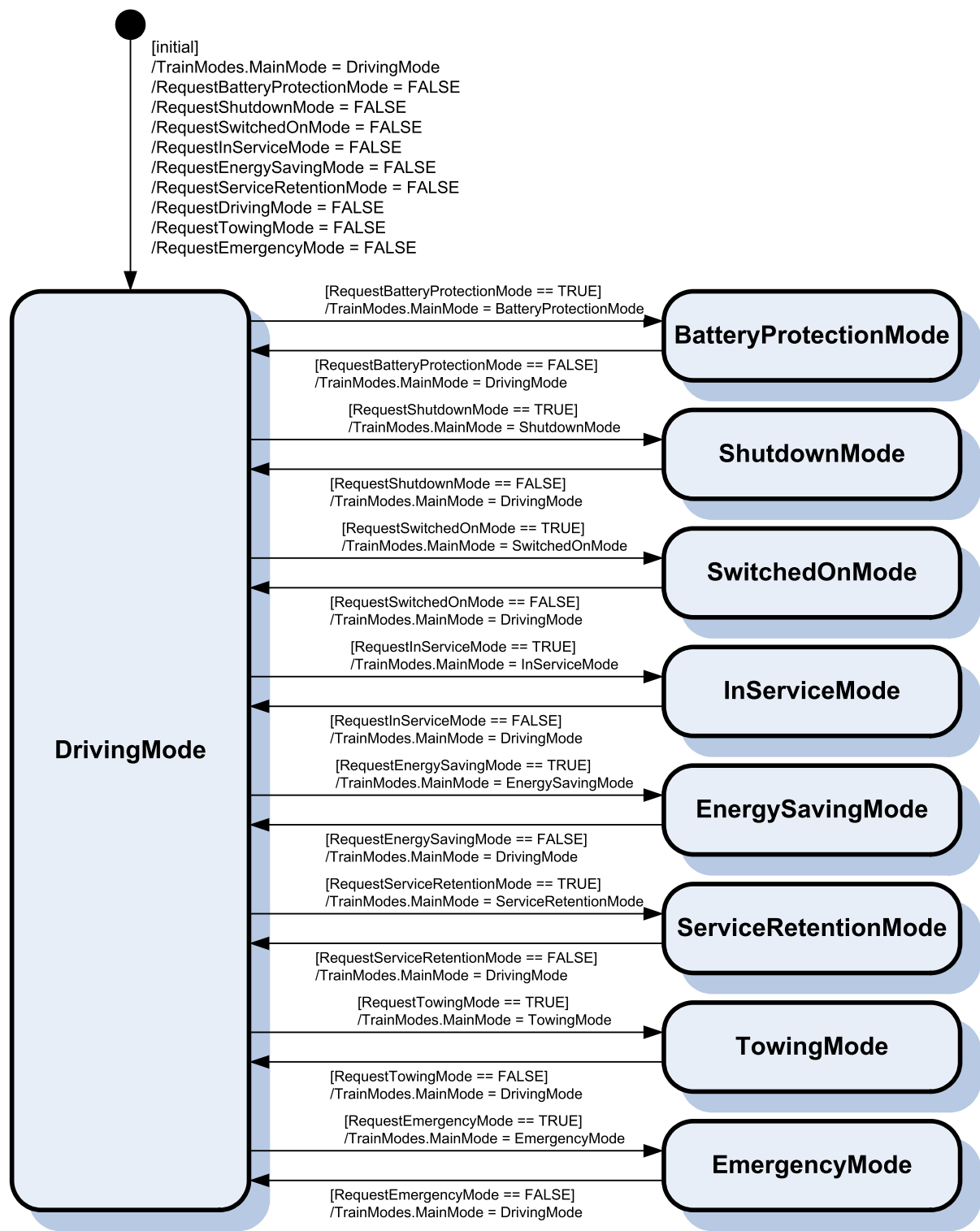

IEC

Figure 20 – Example train modes state diagram

6.2.5 Other train modes

6.2.5.1 General

The description of the other train modes is informative, the normative requirements regarding the applications will be defined in the corresponding application profile. The mentioned “ID card reader” in the subsequent subclauses is only an example for an identification device. No specific implementation is required by this document.

6.2.5.2 Cleaning mode

In mode CleaningMode the train is prepared for cleaning and required devices are instructed to support this (e.g. lighting, power outlets).

6.2.5.3 Coupling mode

The mode CouplingMode applies to the operational scenario: the appropriate coupler covers are open and the speed is limited at 3 km/h. If there is no coupler covers, then the train inauguration by the TCMS informs the driver about the detected train composition. The other train to be coupled can be in any configuration. But coupling will not result in successful train inauguration in “self protection configuration”: the driver detects the self protection unit during the train inauguration.

The activation criteria is for example a soft-key “coupling” in the train driver display.

TCMS ensures that only one cab is activated as master. TCMS does not accept another ID card in parallel and in this case while running ignore any further ID-card and in stand-still trigger a train-wide traction-inhibition.

TCMS ensures that coupling can be performed in any possible train configuration.

During connection of the couplers, TCMS accepts the presence of two ID cards until the coupling is finished.

All functions are available from the master cab.

Other cabs than the master cab can only issue "local" commands not related to the train. TCMS will ignore all train-wide commands from these other cabs and the driver in the master cab will be informed about this situation by the train driver display.

Speed is limited by TCMS at 3 km/h and can be varied by the driver using the speed selector linear between 0 and 3 km/h.

TCMS ensures that the selected speed is maintained and will not be exceeded.

After successful train coupling, the train composition is automatically entered and the holding brakes or a full service brake are train-wide applied. The driver confirms the train-composition in the train driver display and then the train is automatically in in-service configuration.

There are two different states of coupling mode:

- a) coupling mode active
The train is driving towards another train for coupling,
- b) coupling mode passive
The train is ready to couple with another train.

6.2.5.4 Noise reduction mode

In mode NoiseReductionMode the train reduces noise emission, e.g. reduced rotation speed of ventilator, as much as possible.

6.2.5.5 Tunnel mode

In mode TunnelMode the devices in the train are instructed to prepare for passing a tunnel, e.g. special operation of the HVAC system.

6.2.5.6 Automatic operation

In mode AutomaticOperation the train operates in automatic operation.

6.2.5.7 Update mode

In mode UpdateMode all devices are allowed to install updates, e.g. software, parameter files.

6.2.5.8 Composition run

In mode CompositionRun the train composition for a closed train is in progress.

6.2.5.9 Washing mode

In mode WashingMode the blowers are switched off and the speed is limited at 3 km/h.

The activation criteria is for example a soft-key “washing” in the drivers display.

However, the soft-key for activating the washing program is only possible if:

- a) the locomotive is stationary;
- b) direction of travel "Forward" or „Reverse“ has been selected;
- c) the traction / dynamic brake controller has been set to "0";
- d) the main circuit breaker has been switched on;
- e) the driver's automatic brake controller is set in running position.

After pushing the soft-key “washing” in the driver display the TCMS sets the speed-limit according to the selected network (e.g. SNCF/Trenitalia: $V_{\text{target}} = 3 \text{ km/h}$, DB: $V_{\text{target}} = (1,5 \pm 0,5) \text{ km/h}$). The ASC-system is switched on automatically in order to maintain the selected speed-limit. TCMS applies automatically the holding brake to secure the train in stand-still. The driver uses the direct brake or the traction / dynamic brake controller in any traction force position in order to release the holding brake and start the train for washing. When the traction / dynamic brake controller is shifted from "Forward" to "0", the locomotive will continue to roll without power (coasting).

TCMS ensures that only one cab is activated as master. TCMS does not accept another ID card in parallel and in this case while running ignore any further ID-card and in stand-still trigger a train-wide traction-inhibition.

Train-wide control can be executed in this configuration from the master cab.

All functions are available from the master cab.

Other cabs than the master cab can only issue "local" commands not related to the train. TCMS will ignore all train-wide commands from these other cabs and the driver in the master cab will be informed about this situation by the train driver display.

Speed can be varied by the driver using the speed-selector linear between 0 km/h and 3 km/h.

By driver-activation of the soft-key “washing finished” (for example) on the train driver display the normal operation is activated again.

6.2.5.10 Shunting mode

The mode ShuntingMode asks for driving with open doors or door control failure.

The activation criteria is rotating switch “door control override”.

In this mode the train can be operated with open doors (for shunting staff) and speed is limited.

The battery main switch is “on”; all low voltage consumers are supplied and all relevant reservoirs are connected to the air consumers.

The following functions are available:

- a) pantograph or shoe gear;
- b) main circuit breaker;
- c) direct braking;
- d) holding brake.

TCMS ensures that only one cab is activated as master. TCMS accepts another ID card in parallel and in this case while running ignore any further ID-card and in stand-still trigger a train-wide traction-inhibition.

The following conditions apply:

- e) leading vehicle is defined (this locomotive in “shunting mode”);
- f) all functions of DDU are available in active cab;
- g) train-wide control can be executed in this mode from the master cab;
- h) all functions are available from the master cab in “shunting mode”;
- i) master cab is able to control the direction of travel.

Other cabs than the master cab can only issue "local" commands in the vehicle and not train-wide commands, interaction with functions controlled from the master cab is interlocked by TCMS.

For ETCS, shunting mode (SH) available in the leading vehicle, ETCS-sleeping mode in other vehicles.

By reset of the rotating switch “door control override” the normal operation mode is activated again.

6.2.5.11 Delivery drive mode

The mode DeliveryDrive is a special case of normal operation, but without passengers.

6.2.5.12 Other train modes interface

The train mode management provides an interface to set the triggers:

- a) RequestCleaningMode
- b) RequestCouplingMode
- c) RequestNoiseReductionMode
- d) RequestTunnelMode
- e) RequestAutomaticOperationMode
- f) RequestUpdateMode
- g) RequestCompositionRun
- h) RequestWashingMode
- i) RequestShuntingMode

j) RequestDeliveryDrive

This interface allows that a combination of the other train modes is active simultaneous. The definition of this interface is not in the scope of this document.

6.2.6 Parameter train_mode

Figure 21 shows the structure of the parameter train_mode:

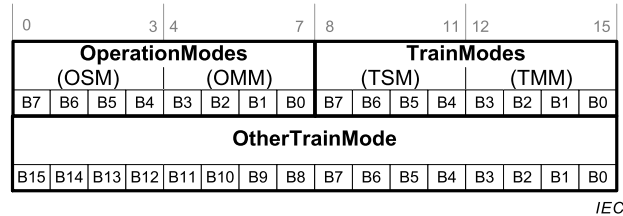

Figure 21 – Parameter train_mode

```

STRUCT_TRAIN_MODE ::= STRUCT
{
  MainMode          UNSIGNED4          -- main mode
  SubMode           UNSIGNED4          -- sub mode
}

TRAIN_MODE ::= RECORD
{
  OperationModes    STRUCT_MAIN_MODE  -- operational state for the
                                       complete train

  TrainModes        STRUCT_MAIN_MODE  -- operational conditions for
                                       the complete train

  OtherTrainMode    BITSET16          -- other operational conditions of
                                       the train
}
    
```

As long as the train mode consist unit has not received the parameter train_mode, it assumes a value of none for the fields OperationModes.MainMode and TrainModes.MainMode and no bit set in OtherTrainMode.

Table 3 defines the values for field OperationModes of parameter train_mode (see 6.2.6).

Table 3 – OperationModes

MainMode	SubMode	Description
0 none	0 .. 15 (not used)	Train mode is unknown
1 NormalOperationMode	Train is in normal operation mode (see 6.2.3.2)	
	0 (none)	Sub mode is not known
	1 .. 4 (reserved)	
	5 (Extension 1)	Project specific extension 1
	6 (Extension 2)	Project specific extension 2
	7 (Extension 3)	Project specific extension 3
	8 .. 15 (reserved)	Reserved for future use
	2 MaintenanceMode	Train is in maintenance mode (see 6.2.3.3)
0 (none)		Sub mode is not known
1 (Service)		E.g. simple checks at HMI are allowed
2 (Inspection)		E.g. check and test-procedures via web interface are allowed
3 (Restoration)		General restoration mode, extended check and test-procedures are allowed, protection functions can be disabled
4 (Improvement)		The train is subject to improvements
5 (Extension 1)		Project specific extension 1
6 (Extension 2)		Project specific extension 2
7 (Extension 3)		Project specific extension 3
8 .. 15 (reserved)		Reserved for future use
3 CommissioningMode	Train is in commissioning mode (see 6.2.3.4)	
	0 .. 15 (reserved)	Sub modes not yet defined and reserved for future use

Table 4 defines the values for field TrainModes of parameter train_mode (see 6.2.6).

Table 4 – TrainModes (1 of 2)

MainMode	SubMode	Description
0 none	0 .. 15 (not used)	Main mode is not known
1 BatteryProtectionMode	0 .. 15 (not used)	Trigger by battery protection against deep discharge (see 6.2.4.2)
2 ShutdownMode	The train is powered off (see 6.2.4.3)	
	0 (none)	Sub mode is not known
	1 (Parking Mode)	E.g. simple checks at HMI are allowed
	2 (Pulled Mode)	E.g. check and test-procedures via web interface are allowed
	3 .. 15 (reserved)	Reserved for future use
3 SwitchedOnMode	The onboard battery net is activated (see 6.2.4.4)	
	0 (none)	Sub mode is not known
	1 (Battery Power Supply)	The train is powered by battery
	2 (Depot Power Supply 1)	The train is powered by auxiliary power 1
	3 (Depot Power Supply 2)	The train is powered by auxiliary power 2
	4 (reserved)	Reserved for future use
	5 (reserved)	Reserved for future use
	6 (Switch Off Initiated)	Main circuit breaker opens soon, all devices prepare for power loss, e.g. persist data and shutdown
	7 .. 15 (reserved)	Reserved for future use
4 InServiceMode	The train is in Service mode a drivers cab is leading (see 6.2.4.5)	
	0 (none)	Sub mode is not known
	1 (Battery Power Supply)	The train is powered by battery
	2 (Depot Power Supply 1)	The train is powered by auxiliary power 1
	3 (Depot Power Supply 2)	The train is powered by auxiliary power 2
	4 (Depot Power Supply 3)	THE train is powered by auxiliary power 3
	5 (Catenary Power Supply)	The train is powered by main power
	6 (Switch Off Initiated)	Main circuit breaker opens soon, all devices prepare for power loss, e.g. persist data and shutdown
	7 (Power System Change)	The voltage system is reconfigured
	8 .. 15 (reserved)	Reserved for future use

Table 4 (2 of 2)

MainMode	SubMode	Description
5 EnergySavingMode		The train parked and powered by main or auxiliary power, the devices reduce power consumption (see 6.2.4.6)
	0 (none)	Sub mode is not known
	1 (Battery Power Supply)	The train is powered by battery
	2 (reserved)	Reserved for future use
	3 (reserved)	Reserved for future use
	4 (Depot Power Supply 3)	The train is powered by auxiliary power 3
	5 (Catenary Power Supply)	The train is powered by main power
	6 (Switch Off Initiated)	Main circuit breaker opens soon, all devices prepare for power loss, e.g. persist data and shutdown
	7 .. 15 (reserved)	Reserved for future use
6 ServiceRetentionMode		Transition state, when changing the leading cab in Service Mode (see 6.2.4.7)
	0 .. 15	see MainMode = 4, Service Mode
7 DrivingMode		The train is driving mode, a driver cab is leading (see 6.2.4.8)
	0 (none)	Sub mode is not known
	1 .. 6 (reserved)	Reserved for future use
	7 (Power System Change)	The voltage system is reconfigured
	8 (Normal Mode)	Normal driving operation
	9 (Transition Mode)	The train passes a neutral section
	10 .. 15 (reserved)	Reserved for future use
8 TowingMode		The train is not powered and is pulled by another traction vehicle, the battery is switched on and auxiliary power may be switched on (see 6.2.4.9)
	0 .. 15 (reserved)	Sub modes not yet defined and reserved for future use
9 EmergencyMode		The emergency operation allows driving the train, even with serious degradation of the train control system with overriding of protection functions, if necessary (see 6.2.4.10)
	0 .. 15 (reserved)	Sub modes not yet defined and reserved for future use
10 .. 15 reserved	0 .. 15 (reserved)	Reserved for future use

Table 5 defines the values for field OtherTrainMode of parameter train_mode.

Table 5 – OtherTrainMode

Bit No	Value	Description
B0 CleaningMode	1	The train is prepared for cleaning (see 6.2.5.2)
	0	else
B1 CouplingMode active	1	The train is driving towards another train for coupling (see 6.2.5.3)
	0	else
B2 CouplingMode passive	1	The train is ready to couple with another train (see 6.2.5.3)
	0	else
B3 NoiseReductionMode	1	The train reduce noise emission (see 6.2.5.4)
	0	else
B4 TunnelMode	1	The devices in the train are requested to prepare for passing a tunnel (see 6.2.5.5)
	0	else
B5 AutomaticOperation	1	The train operates in automatic operation (see 6.2.5.6)
	0	else
B6 UpdateMode	1	All devices are allowed to install updates (see 6.2.5.7)
	0	else
B7 CompositionRun	1	The train composition for a closed train is in progress (see 6.2.5.8)
	0	else
B8 WashingMode	1	The train is prepared to pass a washing plant (see 6.2.5.9)
	0	else
B9 ShuntingMode	1	The train is shunted, the speed is limited (see 6.2.5.10)
	0	else
B10 DeliveryDrive	1	The Train drives without passengers (see 6.2.5.11)
	0	else
B11 .. B12	1	Reserved
	0	Reserved

7 Application profiles

7.1 Door system application profile

7.1.1 Scope

Subclause 7.1 is applicable to all consists (traction units, driving trailers, multiple units, and passenger coaches) that are equipped with a train backbone in accordance with IEC 61375-1 and with doors to be controlled remote.

Other kinds of rolling stock, e.g. EMUs, DMUs (see 3.2) and high-speed trains should comply with this clause in order to develop the remote door control application based on this technical specification and to achieve interoperability.

Clause 7 does not standardize either the implementation of the functions in the individual vehicles, or the design and arrangement of the control equipment, but only the application interface between the vehicles via the communication connection using the train backbone. However, a standardized basic behaviour and basic functionality of the subsystem door providing certain remote control functions is expected.

7.1.2 Door system breakdown structure

According to the general application architecture (see 4.1), Figure 22 illustrates the distribution of the components of the door system.

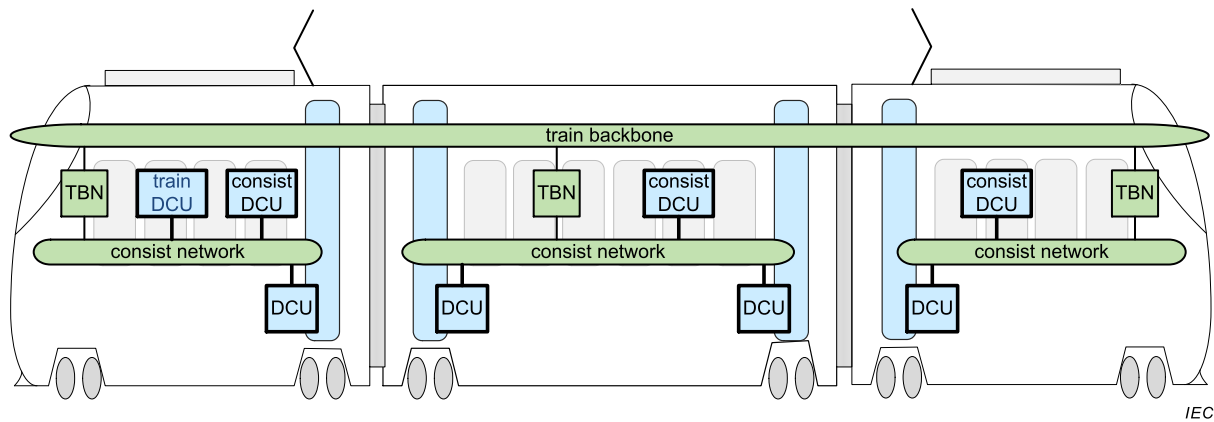

Figure 22 – Distribution structure of the door application

Figure 23 illustrates the component structure of the door system with its interfaces to the TCMS.

This technical specification does not require a specific consist network. Either a consist network according to IEC 61375 or any other network may be deployed, because the consist internal implementation is not in the scope of this document.

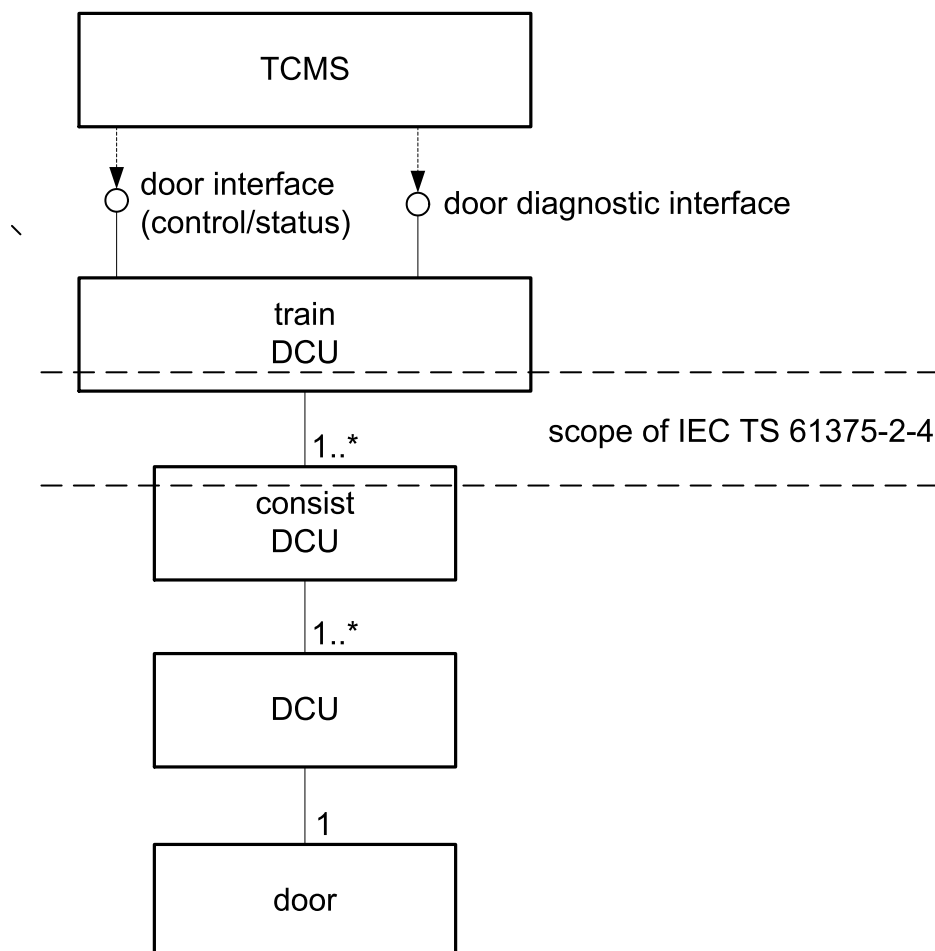

Figure 23 – Architecture of the door system

IEC

The TCMS uses the interfaces of the door system provided by the train DCU to control the functions of the door application.

The train door control unit (DCU) is the function leader, and is the controlling part for all doors in the train.

The consist DCU is the function follower, and is the agent for one consist (network).

The DCU is the function device, which is responsible for a physical door.

The door is the physical device dedicated to the DCU.

7.1.3 Door types

Referring to UIC leaflet 556 the following door types are identified:

- a) Entry doors;
- b) Interconnecting doors;
- c) Entry doors of sleeping cars;
- d) Interconnecting doors of sleeping cars;
- e) WC doors.

WC doors are not considered further in this document, because the use case in UIC leaflet 556 was possibly inspired by WC systems without closed water circuit.

Figure 24 shows the door types and their principal location in the consists.

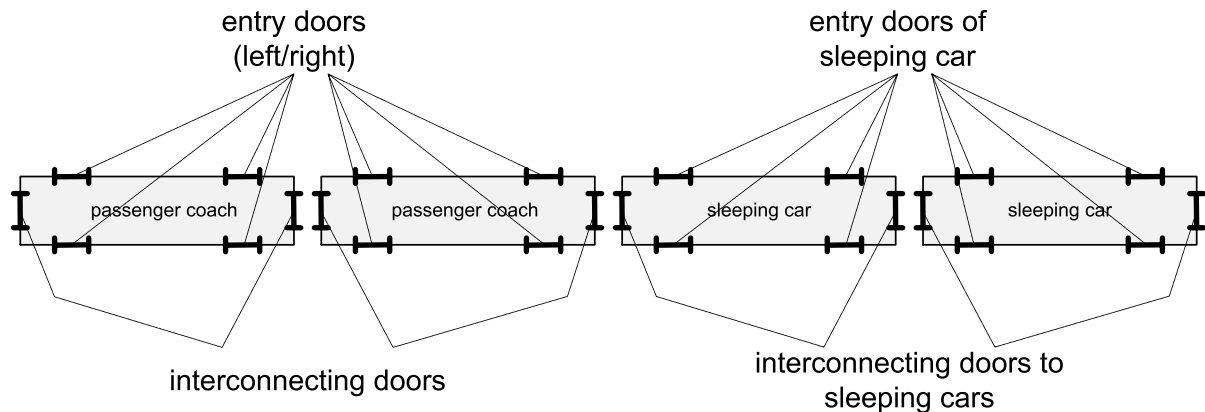

IEC

Figure 24 – Door types

Depending of the door type, different communication paths are chosen. The following figures show that the communication paths cross consist boundaries and therefore are relevant for the train backbone and this technical specification.

Figure 25 shows the communication path for all entry doors, side selective. Source of the request is the driver or train attendant, sink are all entry doors on the selected side.

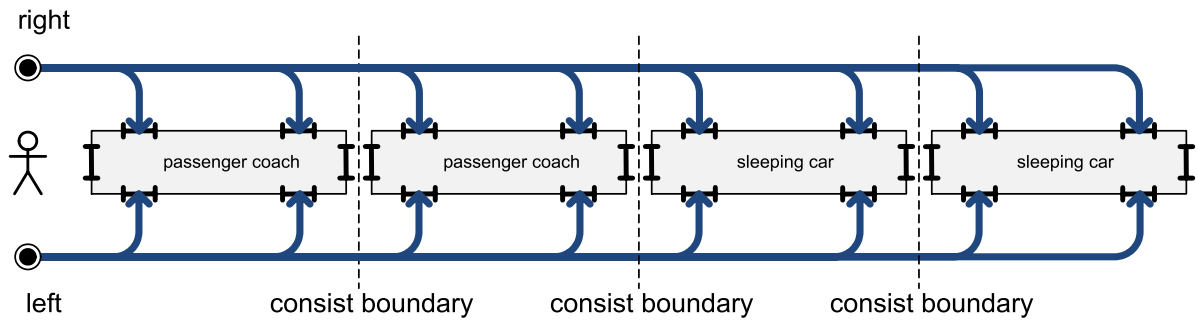

IEC

Figure 25 – Communication path for entry doors

Figure 26 shows the communication path for the adjacent interconnecting doors of neighbouring consists. Source of the request is the interconnecting door of one consist, sink is the adjacent interconnecting door of the neighbouring consist.

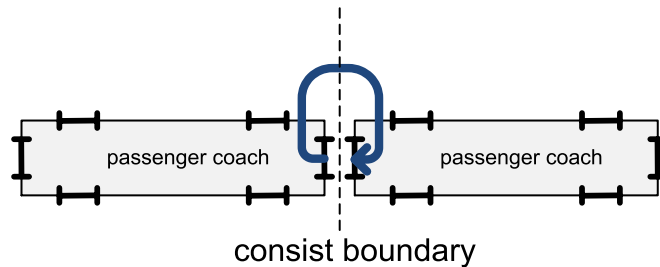

IEC

Figure 26 – Communication path for interconnecting doors

Figure 27 the communication path for all entry doors of all sleeping cars. Source of the lock or release request is the operation of the special conductor's door control switch in the sleeping car.

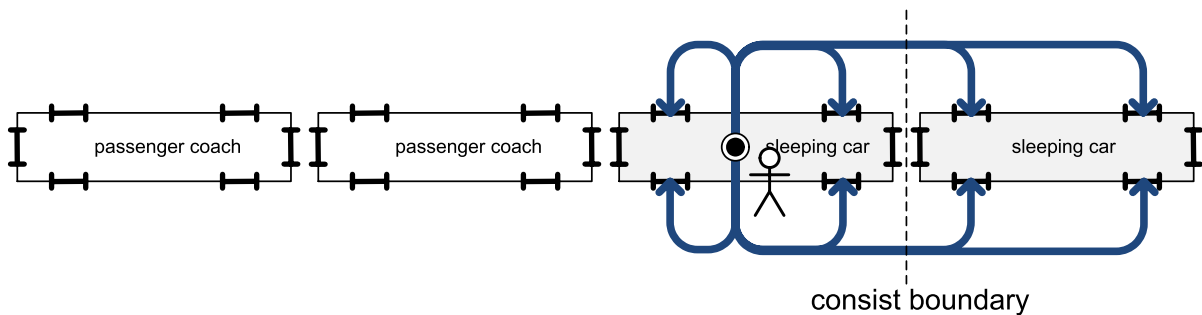

IEC

Figure 27 – Communication path for entry doors of sleeping cars

Figure 28 the communication path for all interconnecting doors of all sleeping cars. Source of the lock or release request is the operation of the special conductor's door control switch in the sleeping car.

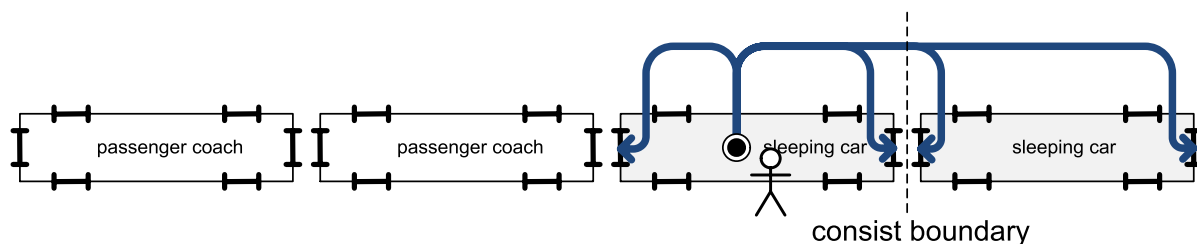

IEC

Figure 28 – Communication path for interconnecting doors of sleeping cars

7.1.4 Door application functional breakdown system

Table 6 shows the functional breakdown structure of the door application illustrated by operation scenarios, which are derived from UIC leaflet 556.

Table 6 – Operation scenarios

Operation scenario	Function	Communication protocol
a) Operation by conductor -remote switch or Operation by driver door closing remote switch	Close all entry doors	Request close all entry doors
b) Operation by conductor-remote switch or Operation by driver door closing remote switch	Interrupt entry door closing	Request cancellation of the remote control command close doors
c) Position of the door control switch of the leading vehicle or Operation of the conductor's door control switch, cancellation after 10' or at V > 5 km/h	Lock or release all left entry doors	Request all entry doors on left locked or released
d) Position of the door control switch of the leading vehicle or Operation of the conductor's door control switch, cancellation. after 10' or at V > 5 km/h	Lock or release all right entry doors	Request all entry doors on right locked or released
e) Process control leading vehicle (operation by driver or signalling)	Extend footstep (coupled with entry doors)	Request release of the footstep extending device
f) Operation of the special conductor's door control switch in the sleeping car	Lock or release all entry doors of the sleeping cars	Request all entry doors of the sleeping cars locked or released
g) Opening of an adjacent interconnecting door in the neighbouring coach	Open adjacent interconnecting door in neighbouring coach	Request adjacent neighbouring interconnecting doors of two neighbouring vehicles operated together
h) Operation of the special conductor's-door control switch in the sleeping car	Interconnecting doors to the sleeping car group locked or released	Request interconnecting doors to sleeping cars locked or released
i) Operation by driver	Prevent or release WC doors	Request WC-use prevented or released

NOTE 1 Operation i) is not defined by this technical specification.

7.1.5 Door application degraded mode

In a distributed system single parts may fail while the rest are still in operation. Detection of the failures and appropriate counter measures need to be defined, to maintain the operation of the door system (see Table 7).

Table 7 – Door application degraded mode

Failure scenario	Detection	Counter measure
TCMS failure	Sink time supervision of control commands (trigger) by the train DCU	The train DCU shall request a safe state for all doors of all consists (e.g. all doors LOCKED)
Train DCU failure	Sink time supervision of control commands (trigger) by the consist DCU	The consist DCU shall request a safe state for all doors of its consist (e.g. all doors LOCKED)
Consist DCU failure	Sink time supervision of status reports from the consist (trigger) by the train DCU	ISOLATE all doors of the failed consist at the train DCU NOTE The consist may be completely out of operation.
DCU failure	Sink time supervision of status reports from the DCU (trigger) by the consist DCU	ISOLATE this failed door of the consist
Door failure	Hardware supervision, which produces failure report from the DCU (trigger)	ISOLATE this failed door of the consist

7.1.6 Door application special mode

Some special cases need to be considered for the operation of the door system (see Table 8).

Table 8 – Door application special mode

Mode	Description
door ATTENDED	When the centralised door closing and locking is activated from a local control, adjacent to a door, it is permissible for this door to remain open when the other doors close and lock. The door control system shall allow the staff to close and lock this door subsequently before departure.

7.1.7 Door system interaction

7.1.7.1 Door trigger overview

The state machines describe the control of the doors. Commands trigger the transition from one state to another (see 7.1.9). The different types of door according to 7.1.3 require different sets of triggers.

7.1.7.2 Triggers for control of entry doors

Figure 29 illustrates the flow of triggers between TCMS and the components of the door system (see Figure 23) to execute the functions according to 7.1.4, Table 6 a) to f).

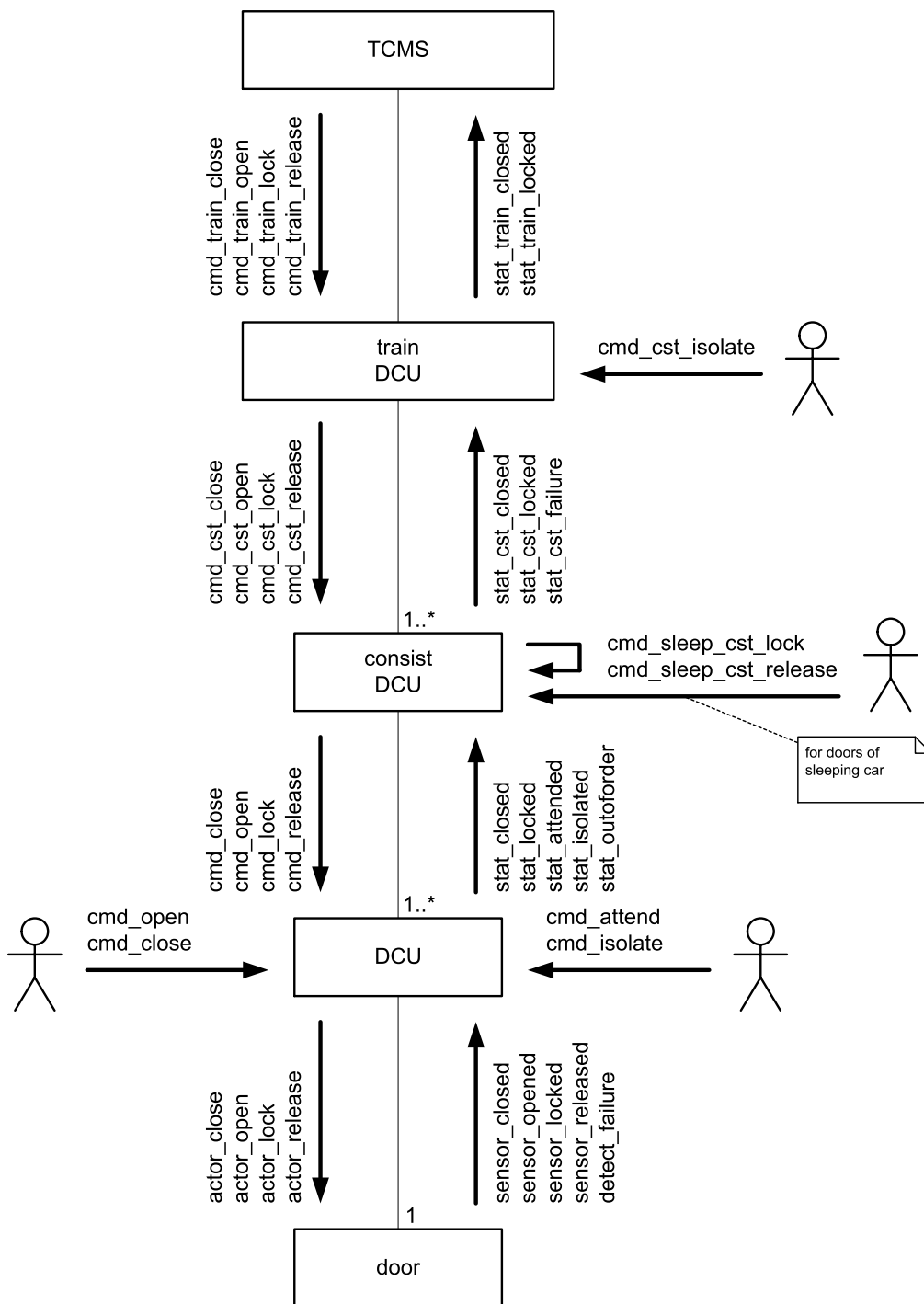

IEC

Figure 29 – Communication flow of triggers for entry doors

Not all triggers result in actual signals between DCUs. If the physical device executing a DCU function fails, it cannot any longer be a source of a trigger. E.g. the trigger stat_isolated may be implemented by a crew manipulator at the consist DCU.

7.1.7.3 Door triggers between TCMS and train DCU

The triggers between TCMS and the train DCU (see Table 9) are informative to describe the door application behaviour.

Table 9 – Triggers between TCMS and train DCU

Trigger	Source	Destination	Description
cmd_train_release	TCMS	train DCU	Request to release all doors
cmd_train_lock	TCMS	train DCU	Request to lock all doors
cmd_train_close	TCMS	train DCU	Request to close all doors
cmd_train_open	TCMS	train DCU	Request to open all doors
stat_train_closed	train DCU	TCMS	Status report, that all doors are CLOSED
stat_train_locked	train DCU	TCMS	Status report, that all doors are LOCKED

The local trigger for the train DCU (see Table 10) is informative to describe the door application behaviour.

Table 10 – Local triggers for the train DCU

Trigger	Source	Destination	Description
cmd_cst_isolate	local input	train DCU	Crew handle/switch to isolate a specific consist from operation, e.g. if this consist is not in normal operation

7.1.7.4 Door triggers between train DCU and consist DCU

The triggers between train DCU and consist DCU (see Table 11) are normative to provide interoperability of consists.

Table 11 – Triggers between train DCU and consist DCU

Trigger	Source	Destination	Description
cmd_cst_release	train DCU	consist DCU	Request to release all doors of consist
cmd_cst_lock	train DCU	consist DCU	Request to lock all doors of consist
cmd_cst_close	train DCU	consist DCU	Request to close all doors of consist
cmd_cst_open	train DCU	consist DCU	Request to open all doors of consist
stat_cst_closed	consist DCU	train DCU	Status report, that all doors of consist are CLOSED
stat_cst_locked	consist DCU	train DCU	Status report, that all doors of consist are LOCKED
stat_cst_failure	consist DCU or train DCU	train DCU	Failure detection either by self- diagnostic of consist DCU or function supervision of consist DCU by train DCU (e.g. process data sink time supervision)

7.1.7.5 Door triggers between consist DCU and DCU for entry doors

The triggers between consist DCU and DCU (see Table 12) are informative to describe the door application behaviour.

Table 12 – Triggers between consist DCU and DCU for entry doors

Trigger	Source	Destination	Description
cmd_release	consist DCU	DCU	Request to release the door
cmd_lock	consist DCU	DCU	Request to lock the door
cmd_close	consist DCU	DCU	Request to close the door
cmd_open	consist DCU	DCU	Request to open the door
stat_closed	DCU	consist DCU	Status report, that the door is CLOSED
stat_locked	DCU	consist DCU	Status report, that the door is LOCKED
stat_attended	DCU	consist DCU	Status report, that the door is ATTENDED
stat_outoforder	DCU	consist DCU	Status report, that the door is in failure condition (unknown position, assume OPENED)
stat_isolated	DCU	consist DCU	Status report CLOSED and LOCKED

The local triggers for the DCU (see Table 13) are informative to describe the door application behaviour.

Table 13 – Local triggers for the DCU

Trigger	Source	Destination	Description
cmd_open	local handle/switch	DCU	Passenger handle/switch to open the door
cmd_close	local handle/switch	DCU	Passenger handle/switch to close the door
cmd_attend	local handle/switch	DCU	Crew handle/switch to mark the door as ATTENDED
cmd_isolate	local handle/switch	DCU	Crew handle/switch to isolate the door from operation

7.1.7.6 Door triggers between DCU and door

The triggers between DCU and door (see Table 14) are informative to describe the door application behaviour.

Table 14 – Triggers between DCU and door

Trigger	Source	Destination	Description
actor_release	DCU	door	Request to physically release the door
actor_lock	DCU	door	Request to physically lock the door
actor_close	DCU	door	Request to physically close the door
actor_open	DCU	door	Request to physically open the door
sensor_closed	door	DCU	Status report, that door is physically CLOSED
sensor_opened	door	DCU	Status report, that door is physically OPENED
sensor_locked	door	DCU	Status report, that door is physically LOCKED
sensor_released	door	DCU	Status report, that door is physically RELEASED
detect_failure	door or DCU	DCU	Failure detection either by self- diagnostic of door or function supervision of door by DCU

7.1.7.7 Triggers for control of interconnecting doors

Figure 30 illustrates the flow of triggers between the components of the door system (see Figure 23) to execute the function according to 7.1.4 Table 6 g).

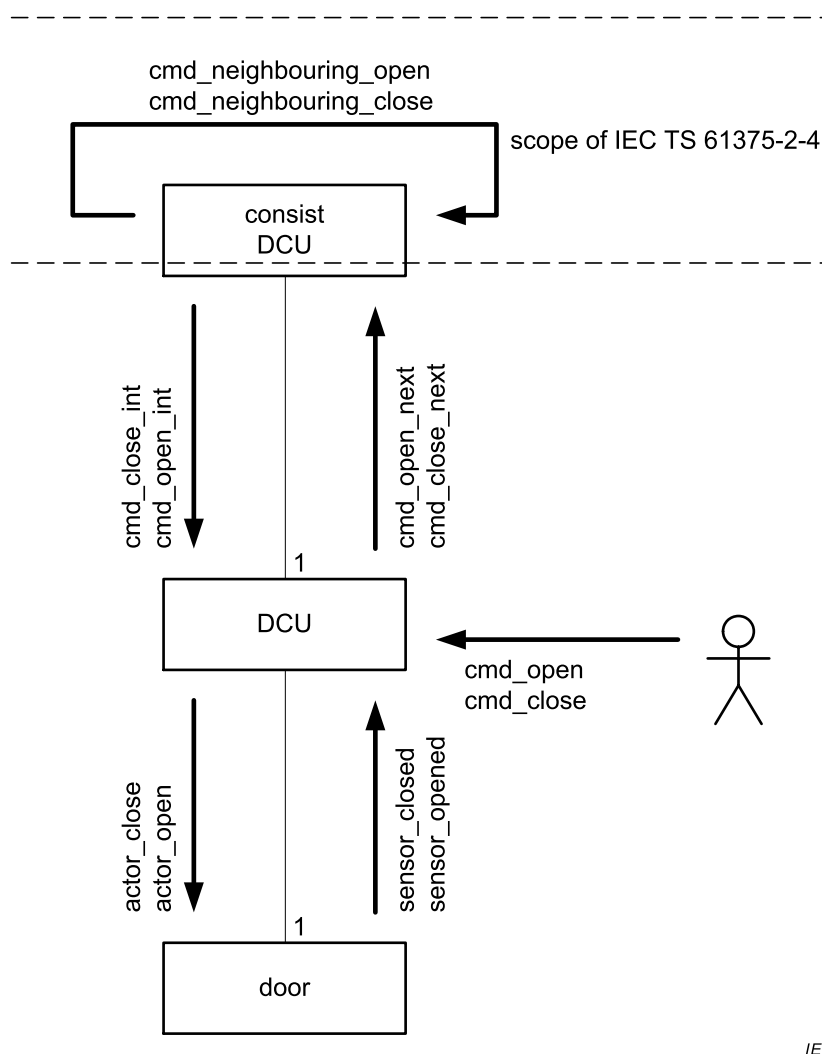

IEC

Figure 30 – Communication flow of triggers for neighbouring interconnecting doors

7.1.7.8 Door triggers between consist DCU and consist DCU for neighbouring interconnecting doors

The triggers between consist DCU and consist DCU (see Table 15) are informative to describe the door application behaviour.

Table 15 – Triggers between consist DCU and consist DCU for neighbouring interconnecting doors

Trigger	Source	Destination	Description
cmd_neighbouring_open	consist DCU	consist DCU	Request to close the neighbouring interconnecting door (from the originating door)
cmd_neighbouring_close	consist DCU	consist DCU	Request to open the neighbouring interconnecting door (from the originating door)

The triggers of Table 15 are not communicated inside the same consist DCU, but between the consist DCUs of the neighbouring consist, as depicted in Figure 31.

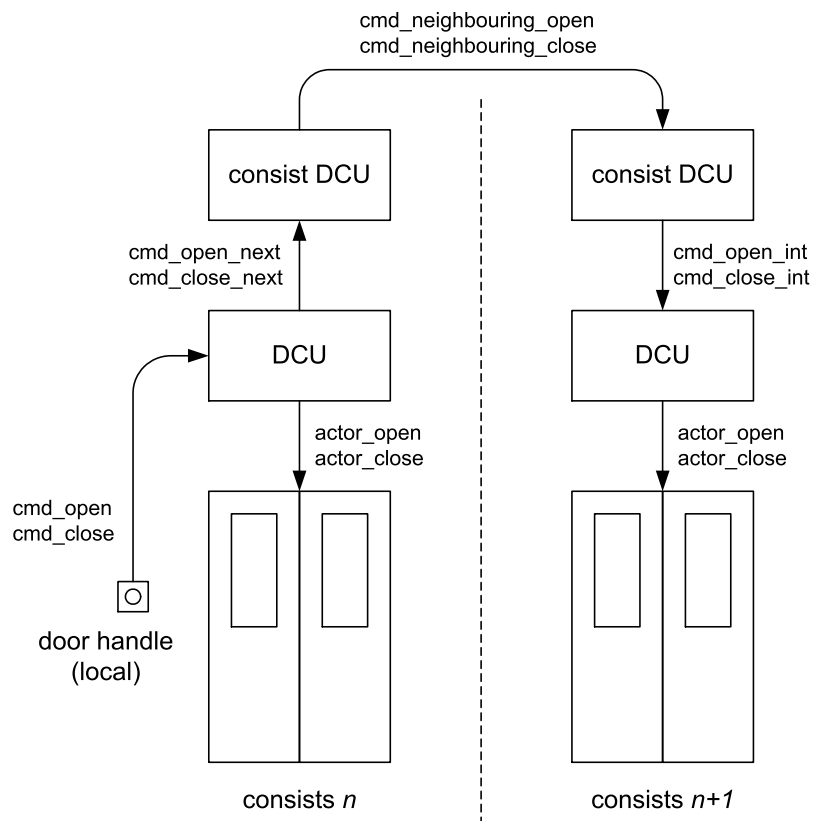

IEC

Figure 31 – Neighbouring consist DCUs for neighbouring interconnecting doors

7.1.7.9 Door triggers between consist DCU and DCU for neighbouring interconnecting doors

The triggers between consist DCU and DCU (see Table 16) are informative to describe the door application behaviour for neighbouring interconnecting doors.

Table 16 – Triggers between consist DCU and DCU for neighbouring interconnecting doors

Trigger	Source	Destination	Description
cmd_open_inter	consist DCU	DCU	Request to open the neighbouring interconnecting door (from the originating door)
cmd_close_inter	consist DCU	DCU	Request to close the neighbouring interconnecting door (from the originating door)
cmd_open_next	DCU	consist DCU	Request to open the neighbouring interconnecting door (to the destination door)
cmd_close_next	DCU	consist DCU	Request to close the neighbouring interconnecting door (to the destination door)

The local triggers for the DCU (see Table 13) are informative to describe the door application behaviour.

7.1.7.10 Triggers for control of interconnecting doors of sleeping cars

Figure 32 illustrates the flow of triggers between the components of the door system (see Figure 23) to execute the function according to 7.1.4 Table 6 h).

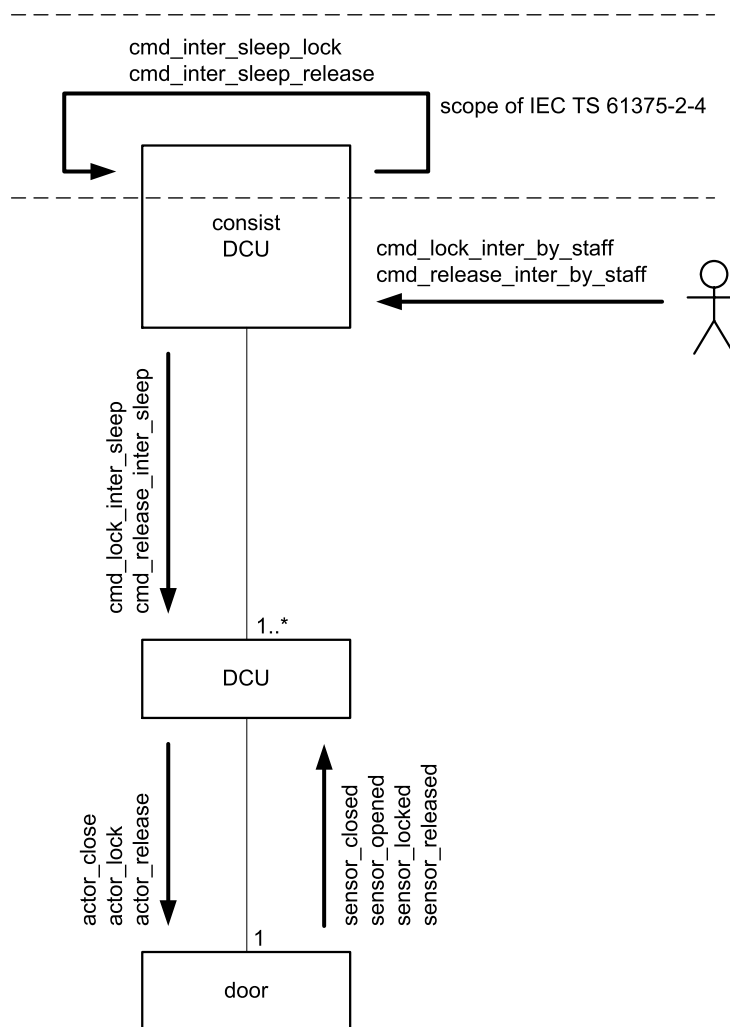

IEC

Figure 32 – Communication flow of triggers for control of interconnecting doors of sleeping cars

7.1.7.11 Door triggers between consist DCU and consist DCU for interconnecting doors of sleeping cars

The triggers between consist DCU and consist DCU (see Table 17) are informative to describe the door application behaviour.

Table 17 – Triggers between consist DCU and consist DCU for interconnecting doors of sleeping cars

Trigger	Source	Destination	Description
cmd_lock_inter_sleep	consist DCU	consist DCU	Propagate request to lock all interconnecting doors of sleeping cars
cmd_release_inter_sleep	consist DCU	consist DCU	Propagate request to release all interconnecting doors of sleeping cars
cmd_lock_inter_by_staff	local handle	consist DCU	Request to lock all interconnecting doors of sleeping cars by staff
cmd_release_inter_by_staff	local handle	consist DCU	Request to release all interconnecting doors of sleeping cars by staff

The triggers of Table 17 are not communicated inside the same consist DCU, but between the consist DCUs of all sleeping cars, as depicted in Figure 31 for interconnecting doors.

7.1.7.12 Door triggers between consist DCU and DCU for interconnecting doors of sleeping cars

The triggers between consist DCU and DCU (see Table 18) are informative to describe the door application behaviour for interconnecting doors of sleeping cars.

Table 18 – Triggers between consist DCU and DCU for interconnecting doors of sleeping cars

Trigger	Source	Destination	Description
cmd_lock_inter_sleep	consist DCU	DCU	Request to lock all interconnecting doors of sleeping cars in the consist
cmd_release_inter_sleep	consist DCU	DCU	Request to release all interconnecting doors of sleeping cars in the consist

The local triggers for the DCU (see Table 13) are informative to describe the door application behaviour.

7.1.8 Side selective operation

The door system shall operate side selective: for left side and for right side.

The behaviour of each side shall be independent.

The triggers defined in 7.1.5 shall be accompanied with a parameter 'side' to allow side selective operation.

Figure 33 illustrates the side selective parameterization of triggers and the handling in the state machines of a DCU.

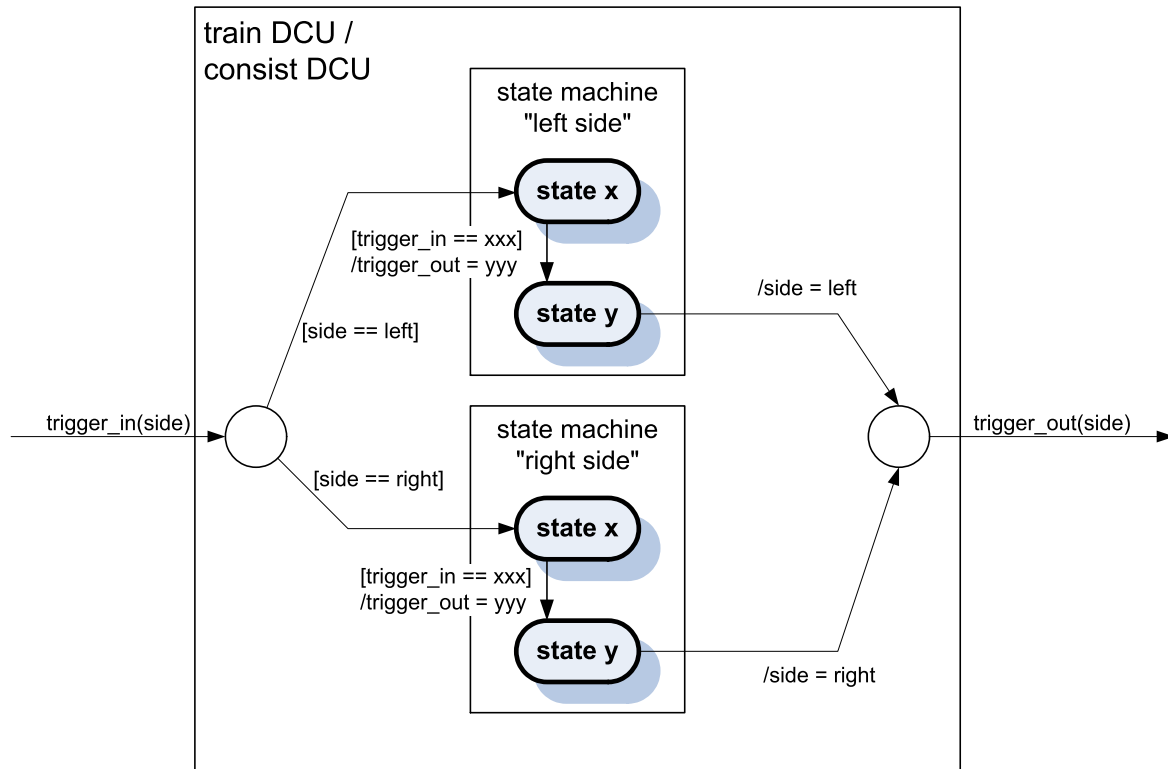

IEC

Figure 33 – Side selective parameterization of triggers

The train DCU and the consist DCU have two versions of its state machine, one for the left side and one for the right side.

When a trigger `trigger_in` with parameter `side` enters a DCU, the DCU decides based on the parameter `side`, to which version of state machine the trigger `trigger_in` is routed. The parameter `side` is stripped off from the trigger `trigger_in`. The trigger `trigger_in` causes a state transition with an associated action, e.g. setting the trigger `trigger_out` for another state machine of the door control. When the trigger `trigger_out` leaves the DCU, the parameter `side` is attached according to the producing state machine.

7.1.9 Door application behaviour

7.1.9.1 General

The behaviour of the door application is described by state machines. The behaviour of the different doors according to 7.1.3 requires different state machines. As a consequence the DCU for a single door and the consist DCU (see 7.1.2) comprise more than one state machine as depicted in Figure 34.

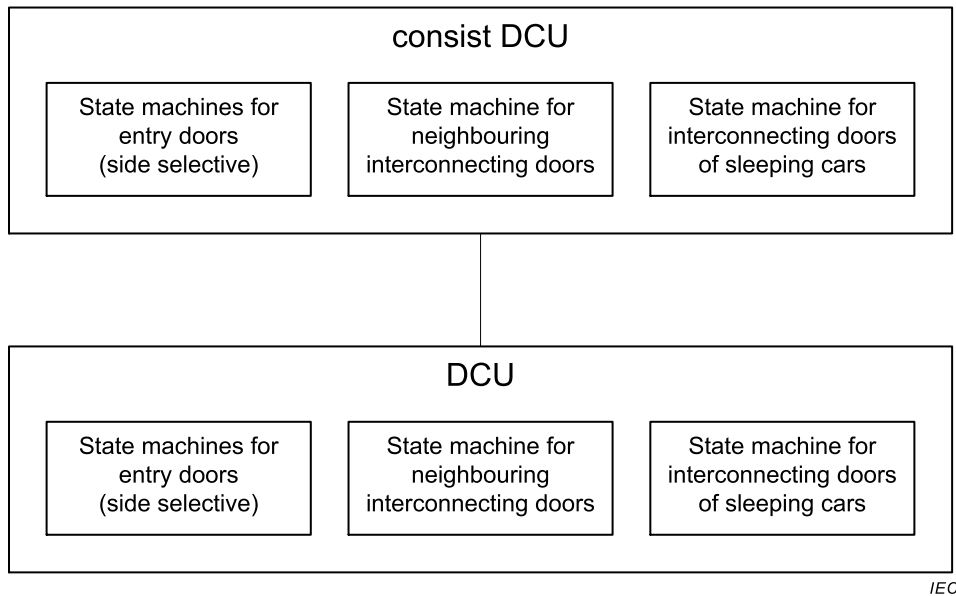

Figure 34 – State machine structure of DCU and consist DCU

The following subclauses 7.1.9.2, 7.1.9.4 and 7.1.9.9 describe the behaviour of the door application for entry doors. The state machines in these clauses are generically described without the parameter side (see 7.1.8).

Subclause 7.1.9.4 describes the behaviour of the door application for neighbouring interconnecting doors.

Subclause 7.1.9.8 describes the behaviour of the door application for interconnecting doors of sleeping cars.

The components TCMS and the physical door (see Figure 23) are not described in detail, but they are used as sources and sinks of triggers.

The description of behaviour is informative to understand the trigger communication between train DCU and consist DCU.

7.1.9.2 Door behaviour

The behaviour of the door itself is not described by a state machine. It is assumed that the triggers for actors of the door (see Table 21) will result in the expected triggers of sensors of the door (see Table 20).

7.1.9.3 DCU behaviour

The DCU behaviour is generally applicable for all types of doors, but not all types of doors deploy all states and state transitions, e.g. neighbouring intermediate doors utilize OPEN and CLOSE function only.

Figure 35 depicts the state diagram of the door control unit for a single exterior door. Table 19 shows the door states used for the state diagram.

Table 19 – DCU state definitions

State	Position	LOCKED	Train Conditions	ISOLATED	ATTENDED	FAILURE
OPENED	open	NO	<ul style="list-style-type: none"> • V < 5 km/h • DCU: available • Train: available 	NO	–	NO
CLOSED	closed	NO	<ul style="list-style-type: none"> • V < 5 km/h • DCU: - • Train: - 	NO	–	NO
LOCKED	closed	YES	<ul style="list-style-type: none"> • V > 5 km/h • DCU: available • Train: available 	NO	–	NO
ISOLATED	closed	YES	–	YES	–	NO
ATTENDED	open	NO	<ul style="list-style-type: none"> • V < 5 km/h • DCU: available • Train: available 	NO	YES	NO
OUT OF ORDER	unknown	unknown	–	NO	–	YES
<any state>	Virtual state representing all other states to reduce diagram complexity.					
“-“ means that the parameter has no influence.						
The speed restrictions in the column train conditions apply to entry doors only.						

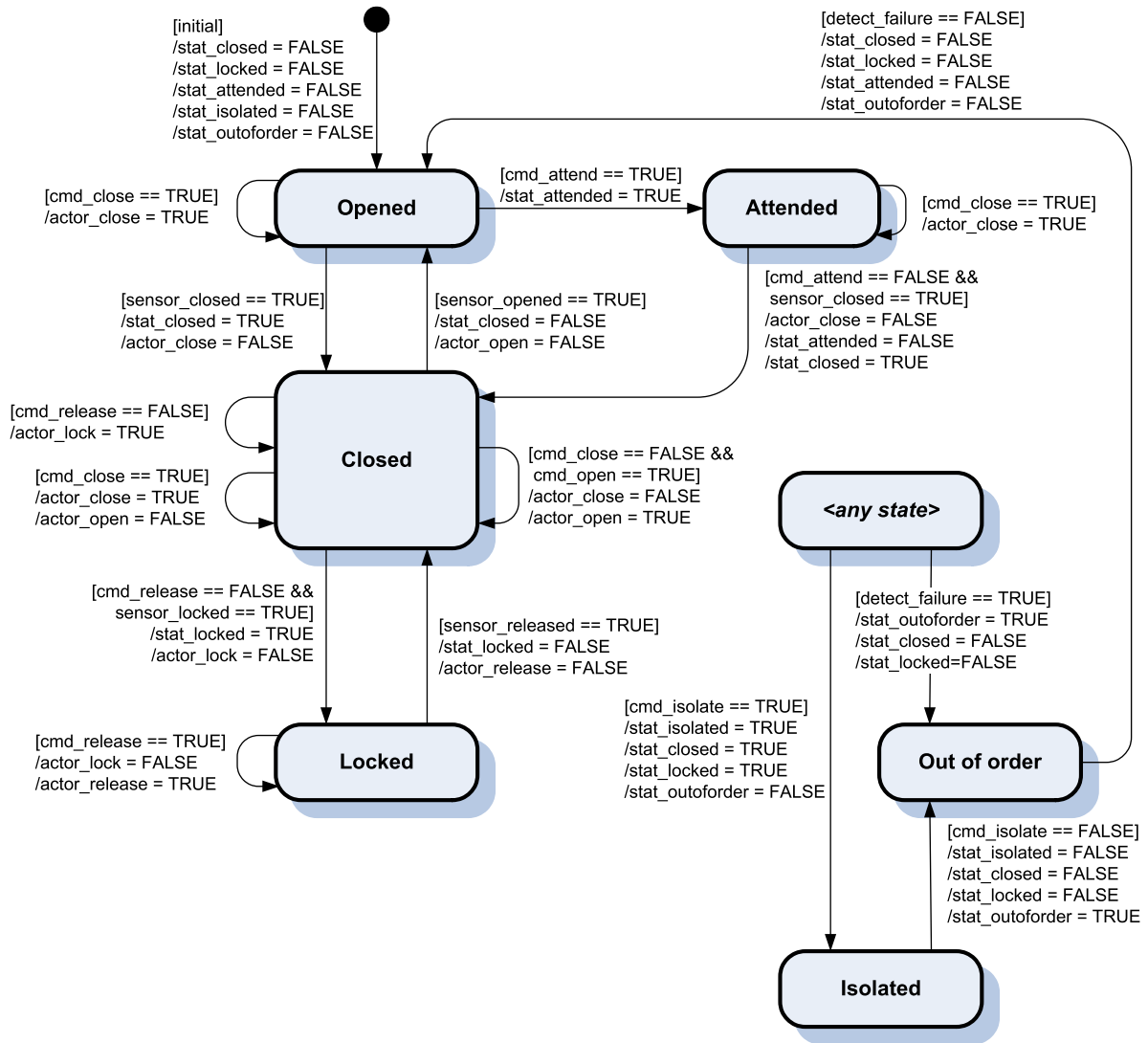

IEC

Figure 35 – DCU state diagram for entry doors

Table 20 and Table 21 describe the triggers and operations of the DCU state machine for entry doors.

NOTE There are no intermediate states like OPENING, CLOSING, RELEASING or LOCKING. These intermediate states are implicitly represented by the current state and the trigger sent to the next state machine. When the next state machine reports the completion of the operation, it sends back the appropriate status trigger, which causes the desired state transition.

Table 20 – DCU triggers for entry doors

Trigger	Description
Initial	Power-up or re-boot of door control unit (DCU); the door shall be assumed opened
cmd_close ^{*)}	TRUE: the door shall be closed
	FALSE: no change of the door position
cmd_open ^{*)}	TRUE: the door shall be opened, only if the trigger cmd_close == FALSE
	FALSE: no change of the door position
cmd_neighbouring_close	TRUE: the neighbouring door shall be closed
	FALSE: no change of the door position
cmd_neighbouring_open	TRUE: the neighbouring door shall be opened
	FALSE: no change of the door position
cmd_release ^{**)}	TRUE: the door shall be released
	FALSE: no change of the door locking state
cmd_lock ^{**)}	TRUE: the door shall be locked
	FALSE: no change of the door locking state
cmd_attend	TRUE: the door shall be handled as ATTENDED and report this to the consist DCU
	FALSE: the door shall not be handled as ATTENDED
cmd_failure	TRUE: the door shall be handled as taken out of order
	FALSE: the door shall not be handled as taken out of order
sensor_closed	TRUE: the door reports, that it is CLOSED
	FALSE: else
sensor_opened	TRUE: the door reports, that it is OPENED
	FALSE: else
sensor_locked	TRUE: the door reports, that it is LOCKED
	FALSE: else
sensor_released	TRUE: the door reports, that it is RELEASED
	FALSE: else
detect_failure	TRUE: the door reports, that it has detected a failure, it shall be assumed OPENED
	FALSE: the door reports, that it is in normal operation
^{*)} These triggers are utilized for all types of doors.	
^{**)} These triggers are utilized for entry doors and neighbouring interconnecting doors of sleeping cars.	

Table 21 – DCU operations for entry doors

Operation	Description
actor_close ^{*)}	TRUE: the door shall close
	FALSE: no action
actor_open ^{*)}	TRUE: the door shall open
	FALSE: no action
actor_lock ^{**)}	TRUE: the door shall be locked
	FALSE: no action
actor_release ^{**)}	TRUE: the door shall be released
	FALSE: no action
stat_closed	TRUE: the DCU reports that the door is CLOSED
	FALSE: else
stat_locked	TRUE: the DCU reports that the door is LOCKED
	FALSE: else
stat_attended	TRUE: the DCU reports that the door is ATTENDED
	NOTE An ATTENDED door can be regarded as a CLOSED door.
	FALSE: else
stat_outoforder	TRUE: the DCU reports that the door is faulty; since there is no reliable information about the state of the door it shall be assumed OPENED
	FALSE: the DCU reports that the door is normal operation
stat_isolated	TRUE: the DCU reports that the door is taken out of operation; since this is an intended operation, the door shall be assumed CLOSED and LOCKED
	FALSE: the DCU reports that the door is not taken out of operation
flag_release_enabled	TRUE: the DCU is allowed to process the trigger cmd_release
	FALSE: the DCU shall not process the trigger cmd_release
*) These operations are utilized for all types of doors.	
**) These operations are utilized for entry doors and neighbouring interconnecting doors of sleeping cars.	

7.1.9.4 DCU behaviour for neighbouring interconnecting doors

Figure 36 depicts the state diagram of the door control unit for a single interconnecting door. Table 22 shows the door states used for the state diagram.

Table 22 – DCU state definitions for neighbouring interconnecting doors

State	Description
Opened_inter	Interconnecting door is OPENED
Closed_inter	Interconnecting door is CLOSED

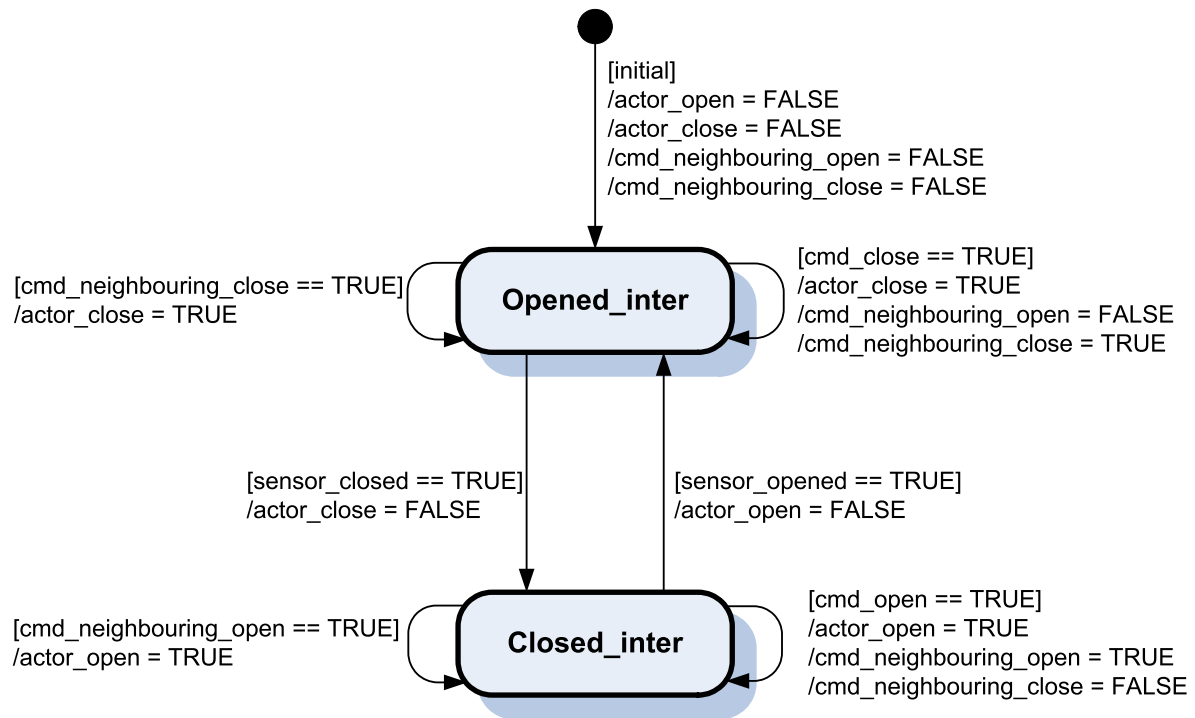

IEC

Figure 36 – DCU state diagram for neighbouring interconnecting doors

See Table 20 and Table 21 for the description of the triggers and operations of the DCU state machine for neighbouring interconnecting doors.

NOTE This state machine is simplified. For example, if the closing of the interconnecting door is in progress and it receives the trigger `cmd_open`, it preferably opens again immediately, but this is an implementation issue, which does not affect the principle of trigger flow at backbone level.

7.1.9.5 DCU behaviour for interconnecting doors of sleeping cars

Figure 37 depicts the state diagram of the door control unit for a single exterior door. Table 23 shows the door states used for the state diagram.

Table 23 – DCU state definitions for interconnecting doors of sleeping cars

State	Description
Released_inter	Interconnecting door of sleeping car is RELEASED
Locked_inter	Interconnecting door of sleeping car is LOCKED

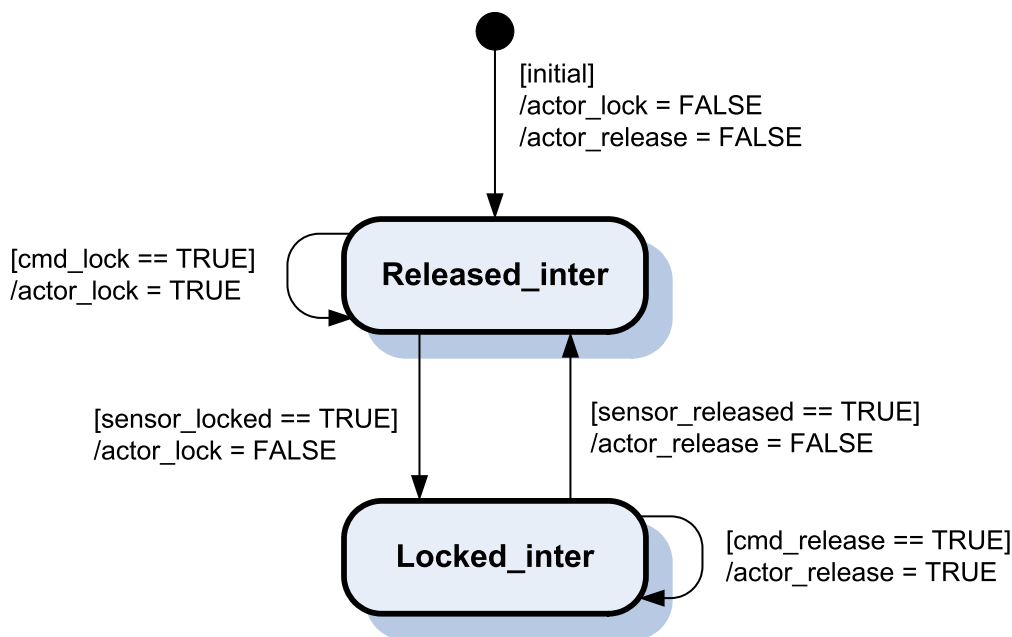

IEC

Figure 37 – DCU state diagram for interconnecting doors of sleeping cars

See Table 20 and Table 21 for the description of the triggers and operations of the DCU state machine for interconnecting doors of sleeping cars.

7.1.9.6 Consist DCU behaviour for entry doors

Figure 38 shows the state diagram of the consist DCU for all entry doors of a consist. For side selective operation, see 7.1.8. Table 24 shows the consist DCU states used for the state diagram.

Table 24 – Consist DCU state definitions for entry doors

State	Position	LOCKED	ISOLATED	FAILURE	Description
Cst_Opened	open	NO	NO	NO	Not all entry doors of the consist are CLOSED (side selective)
Cst_Closed	closed	NO	NO	NO	All entry doors of the consist are CLOSED (side selective)
Cst_Locked	closed	YES	-	NO	All entry doors of the consist are LOCKED (side selective)
Cst_Out_of_Order	open	NO	NO	YES	Consist is out of order, entry doors are assumed OPENED and not LOCKED
<any state>	Virtual state representing all other states to reduce diagram complexity.				
“-“ means that the parameter has no influence.					

The entry doors of sleeping cars shall be lockable by operation of the special conductor’s door control switch in the sleeping car. Table 25 shows the additional states used to control the release of the entry doors.

Table 25 – Additional consist DCU state definitions for entry doors of sleeping cars

State	Purpose
Release enabled	The entry doors of the sleeping car can be released by the trigger cmd_release.
Release disabled	The entry doors of the sleeping car shall not be released by the trigger cmd_release. Furthermore the triggers cmd_close and cmd_lock shall be implied to lock these doors.

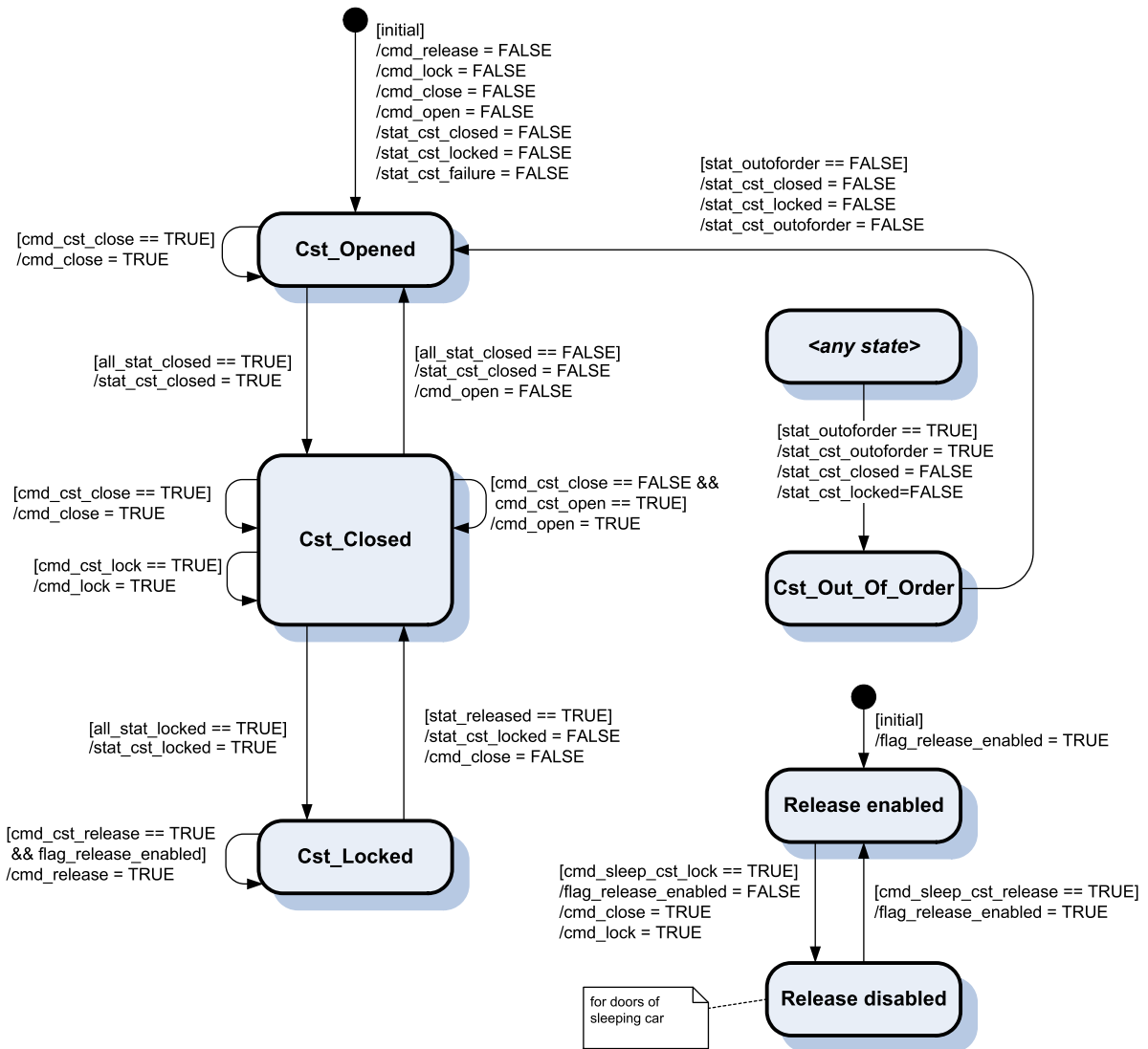

Figure 38 – Consist DCU state diagram for entry doors

Table 26, Table 27 and Table 28 describe the triggers, conditions and operations of the consist DCU state machine for entry doors.

IEC

Table 26 – Consist DCU Triggers for entry doors

Trigger	Description
Initial	Power-up or re-boot of consist door control unit (consist DCU); all doors of the consist shall be assumed OPENED; no requests to the DCU are pending
cmd_cst_close	TRUE: all entry doors of the consist shall be closed (side selective) This trigger shall override the trigger cmd_cst_open.
	FALSE: no change of the entry door position
cmd_cst_open	TRUE: all entry doors of the consist shall be opened, only if the trigger cmd_cst_close == FALSE (side selective)
	FALSE: no change of the entry door position
cmd_cst_release	TRUE: all entry doors of the consist shall be released (side selective)
	FALSE: no change of the entry door locking state
cmd_cst_lock	TRUE: all entry doors of the consist shall be locked (side selective) This trigger shall override the trigger cmd_cst_release.
	FALSE: no change of the entry door locking state
stat_closed	TRUE: a DCU reports that the entry door is CLOSED, to be used in condition all_stat_closed
	FALSE: else
stat_locked	TRUE: a DCU reports that the door is LOCKED, to be used in condition all_stat_locked
	FALSE: else
stat_attended	TRUE: the DCU reports that the entry door is ATTENDED NOTE An ATTENDED entry door can be regarded as a CLOSED door.
	FALSE: else
stat_outoforder	TRUE: the DCU reports that not all entry doors are in normal operation, it shall be assumed not all doors are CLOSED and LOCKED
	FALSE: the DCU reports that all entry doors are in normal operation
stat_isolated	TRUE: the DCU reports that the entry door is ISOLATED; since this is an intended operation, the door shall be assumed CLOSED and LOCKED
	FALSE: the DCU reports that the entry door is not ISOLATED (i.e. can be remotely controlled, if not OUT OF ORDER)
cmd_sleep_cst_lock	Emits triggers cmd_close and cmd_lock and disables the effect of the trigger cmd_release
cmd_sleep_cst_release	Enables the effect of the trigger cmd_release

Table 27 – Consist DCU Conditions for entry doors

Condition	Description
all_stat_closed	Logical AND over triggers stat_closed from all DCUs; if a DCU reports stat_attended == TRUE, it shall be handled as stat_closed == TRUE (side selective)
all_stat_locked	Logical AND over triggers stat_locked from all DCUs (side selective)

Table 28 – Consist DCU Operations for entry doors

Operation	Description
cmd_close	TRUE: all the entry doors of the consist shall be closed (side selective)
	FALSE: no change of the entry door position
cmd_open	TRUE: all the entry doors of the consist shall be opened, only if the trigger cmd_cst_close == FALSE (side selective)
	FALSE: no change of the entry door position
cmd_release	TRUE: all the entry doors of the consist shall be released (side selective)
	FALSE: no change of the entry door locking state
cmd_lock	TRUE: all the entry doors of the consist shall be locked (side selective)
	FALSE: no change of the entry door locking state
stat_cst_closed	TRUE: the consist DCU reports that all the entry doors of the consist are CLOSED (side selective)
	FALSE: else
stat_cst_locked	TRUE: the consist DCU reports that all the entry doors of the consist are LOCKED (side selective)
	FALSE: else
stat_cst_failure	TRUE: the consist DCU reports that not all entry doors of the consist are in normal operation; the doors of this consist shall be assumed OPENED
	FALSE: the DCU reports that all entry doors of the consist are in normal operation

7.1.9.7 Consist DCU behaviour for neighbouring interconnecting doors

Figure 39 depicts the state diagram of the consist door control unit for neighbouring interconnecting doors of neighbouring consist. Table 29 shows the consist DCU states used for the state diagram.

Table 29 – Consist DCU state definitions for neighbouring interconnecting doors

State	Description
Cst_Operate_inter	There is only one single state, because the inbound triggers are directly forwarded as operations, i.e. triggers to the next state machine

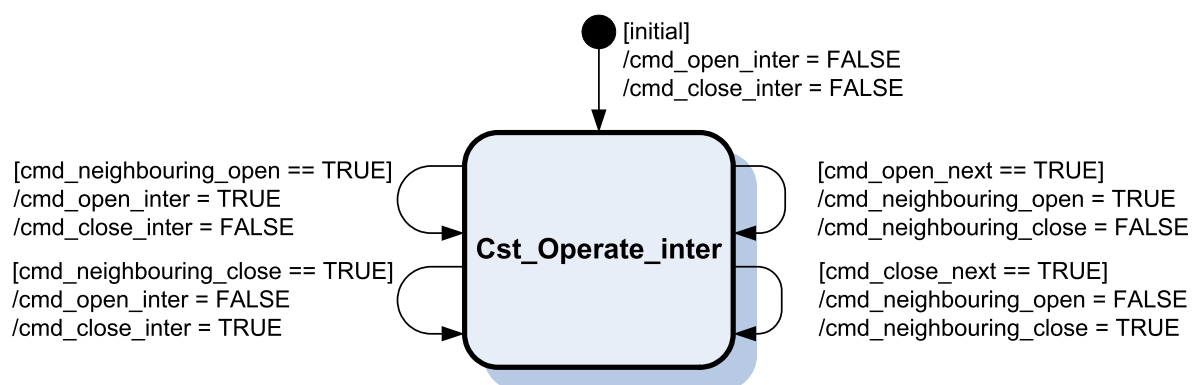

IEC

Figure 39 – Consist DCU state diagram for neighbouring interconnecting doors

Table 30 and Table 31 describe the triggers and operations of the consist DCU state machine for entry doors.

Table 30 – Consist DCU Triggers for neighbouring interconnecting doors

Trigger	Description
Initial	Power-up or re-boot of consist door control unit (consist DCU); all interconnecting doors of the consist shall be assumed OPENED; no requests to the DCU are pending
cmd_neighbouring_open	TRUE: receive, that the neighbouring connecting door of the neighbouring consist shall be opened
	FALSE: no change of the neighbouring connecting door position
cmd_neighbouring_close	TRUE: receive, that the neighbouring connecting door of the neighbouring consist shall be closed
	FALSE: no change of the neighbouring connecting door position
cmd_open_next	TRUE: originate, that the neighbouring connecting door of the neighbouring consist shall be opened
	FALSE: no change of the neighbouring connecting door position
cmd_close_next	TRUE: originate, that the neighbouring connecting door of the neighbouring consist shall be closed
	FALSE: no change of the neighbouring connecting door position

Table 31 – Consist DCU Operations for neighbouring interconnecting doors

Operation	Description
cmd_open_inter	TRUE: the interconnecting door which corresponds to the originating interconnecting door shall be opened
	FALSE: no change of the interconnecting door position
cmd_close_inter	TRUE: the interconnecting door which corresponds to the originating interconnecting door shall be closed
	FALSE: no change of the interconnecting door position
cmd_neighbouring_open	TRUE: propagate, that the neighbouring connecting door of the neighbouring consist shall be opened
	FALSE: no change of the neighbouring connecting door position
cmd_neighbouring_close	TRUE: propagate, that the neighbouring connecting door of the neighbouring consist shall be closed
	FALSE: no change of the neighbouring connecting door position

7.1.9.8 Consist DCU behaviour for interconnecting doors of sleeping cars

Figure 40 depicts the state diagram of the consist door control unit for interconnecting doors of sleeping cars. Table 32 shows the consist DCU states used for the state diagram.

Table 32 – Consist DCU state definitions for interconnecting doors of sleeping cars

State	Description
Cst_Operate_inter_sleep	There is only one single state, because the inbound triggers are directly forwarded as operations, i.e. triggers to the next state machine

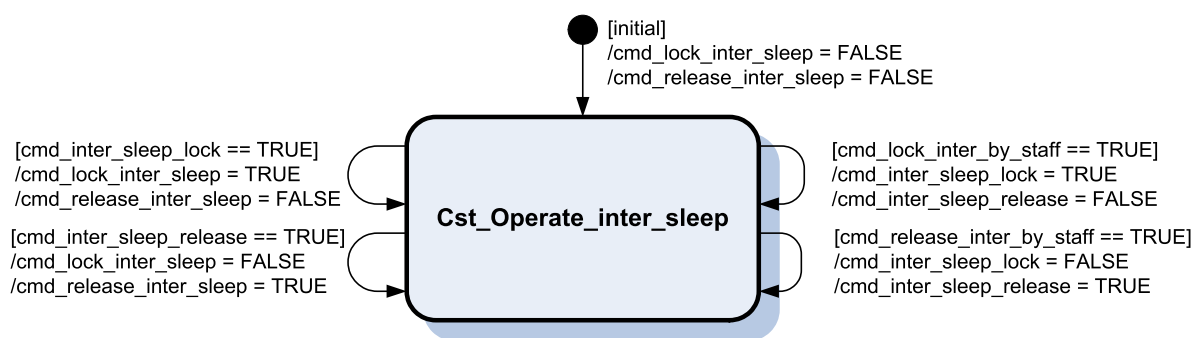

IEC

Figure 40 – Consist DCU state diagram for interconnecting doors of sleeping cars

Table 33 and Table 34 describe the triggers and operations of the consist DCU state machine for interconnecting doors of sleeping cars.

Table 33 – Consist DCU Triggers for interconnecting doors of sleeping cars

Trigger	Description
Initial	Power-up or re-boot of consist door control unit (consist DCU); all interconnecting doors of the consist shall be assumed OPENED; no requests to the DCU are pending
cmd_release_inter_by_staff	TRUE: originate, that the interconnecting doors of sleeping cars shall be released
	FALSE: no change of the position of the connecting door of sleeping car
cmd_lock_inter_by_staff	TRUE: originate, that the interconnecting doors of sleeping cars shall be locked
	FALSE: no change of the position of the connecting door of sleeping car
cmd_inter_sleep_release	TRUE: receive, that the interconnecting doors of sleeping cars shall be released
	FALSE: no change of the position of the connecting door of sleeping car
cmd_inter_sleep_lock	TRUE: receive, that the interconnecting doors of sleeping cars shall be locked
	FALSE: no change of the position of the connecting door of sleeping car

Table 34 – Consist DCU Operations for interconnecting doors of sleeping cars

Operation	Description
cmd_release_inter_sleep	TRUE: the interconnecting door shall be released
	FALSE: no change of the interconnecting door position
cmd_lock_inter_sleep	TRUE: the interconnecting door shall be locked
	FALSE: no change of the interconnecting door position
cmd_inter_sleep_release	TRUE: propagate, that the interconnecting doors of sleeping cars shall be released
	FALSE: no change of the position of the connecting door of sleeping car
cmd_inter_sleep_lock	TRUE: propagate, that the interconnecting doors of sleeping cars shall be locked
	FALSE: no change of the position of the connecting door of sleeping car

7.1.9.9 Train DCU behaviour

Figure 41 shows the state diagram of the train door control unit for all doors of all consists. For side elective operation, see 7.1.8. Table 35 shows the train DCU states used for the state diagram.

Table 35 – Train DCU state definitions

State	Position	LOCKED	ISOLATED	FAILURE	Description
Train_Cst_Opened	open	NO	NO	NO	For each consist: not all doors of this consist are CLOSED (side selective)
Train_Cst_Closed	closed	NO	NO	NO	For each consist: all doors of this consist are CLOSED (side selective)
Train_Cst_Locked	closed	YES	NO	NO	For each consist: all doors of this consist are LOCKED (side selective)
Train_Cst_Out_of_Order	open	NO	NO	YES	For each consist: this consist is out of order, all its doors are assumed OPENED and not LOCKED
Train_Cst_Isolated	closed	YES	YES	-	For each consist: this consist is ISOLATED, doors are assumed CLOSED and LOCKED
Train_Locked	closed	YES	-	-	All doors of the train are LOCKED or ISOLATED (side selective)
<any state>	Virtual state representing any state to reduce diagram complexity.				
“-“ means that the parameter has no influence.					

Table 36 – Train DCU triggers

Trigger	Description
Initial	Power-up or re-boot of train door control Unit (train DCU); all doors of the consist shall be assumed OPENED; no requests to the consist DCUs are pending
cmd_train_close	TRUE: all doors of the train shall be closed (side selective)
	FALSE: no change of the door position
cmd_train_open	TRUE: all doors of the train shall be opened, only if the trigger cmd_train_close == FALSE (side selective)
	FALSE: no change of the door position
cmd_train_release	TRUE: all doors of the train shall be released (side selective)
	FALSE: no change of the door locking state
cmd_train_lock	TRUE: all doors of the train shall be locked (side selective)
	FALSE: no change of the door locking state
cmd_cst_isolate	TRUE: all doors for a specific consist are isolated (side selective)
	FALSE: all doors for a specific consist are not isolated (side selective)
stat_cst_closed	TRUE: a consist DCU reports that all doors of the consist are CLOSED, to be used in condition all_stat_cst_closed
	FALSE: else
stat_cst_locked	TRUE: a consist DCU reports that that all doors of the consist are LOCKED, to be used in condition all_stat_cst_locked
stat_cst_failure	TRUE: the consist DCU reports, that it has detected a failure, all doors of this consist shall be assumed OPENED
	NOTE This trigger can be generated inside the train DCU by operational supervision of the consist DCU.
	FALSE: the consist DCU is in normal operation

Table 37 – Train DCU conditions

Condition	Description
locked_or_isolated	For each consist, this condition is the logical OR of the trigger cmd_cst_isolate with the logical AND of the triggers cmd_train_lock and stat_cst_locked, i.e. all doors for this consist are either LOCKED or ISOLATED. (side selective)
all_locked_or_isolated	For all consists, this condition is the logical AND of the condition locked_or_isolated, i.e. all doors of the train are either LOCKED or ISOLATED. (side selective)
comp_changed	When the train composition changes (e.g. coupling, decoupling) the instances of the sub state machines for each consist need to be reconfigured according to the actual train topology.

Table 38 – Train DCU operations

Operation	Description
cmd_cst_close	TRUE: all the doors of all consists shall be closed (side selective)
	FALSE: no change of the door position
cmd_cst_open	TRUE: all the doors of all consists shall be opened, only if the trigger cmd_train_close == FALSE (side selective)
	FALSE: no change of the door position
cmd_cst_release	TRUE: all the doors of all consists shall be released (side selective)
	FALSE: no change of the door locking state
cmd_cst_lock	TRUE: all the doors of all consists shall be locked (side selective)
	FALSE: no change of the door locking state
stat_train_closed	TRUE: the train DCU reports that all the doors of the train are CLOSED (side selective)
	FALSE: else
stat_train_locked	TRUE: the train DCU reports that all the doors of the train are LOCKED (side selective)
	FALSE: else
reconfigure_consists	Reconfigure the train DCU state machines according to the actual train topology.

Annex A (normative)

Profile data definitions

A.1 Engineering units

When referring to physical quantities, the following definitions in Table A.1 and Table A.2 shall be used. These engineering units shall be applied for encoding data information to be stored or exchanged between applications.

Table A.1 – Physical quantities (e.g. 16 bit integer type)

Physical quantity [Unit]	Default resolution (unit / bit) 0x1 =	Resulting in a maximum value stored in a 16-bit size of type Integer16
Acceleration/Deceleration [m/s ²]	0,001 m/s ²	32,767 m/s ²
Speed of rotation per minute [rpm]	1 rpm	32 767 rpm
Pressure [bar]	0,001 bar	32,767 bar
Frequency [Hz]	0,1 Hz	3 276,7 Hz
Force [kN]	0,1 kN	3 276,7 kN
Length/Wheel diameter [mm]	0,1 mm	3 276,7 mm
Power [kW]	1 kW	32 767 kW
Energy [kWh]	1 kWh	32 767 kWh
Mass [t]	0,05 t	1 638,35 t
Velocity (Speed) [km/h]	0,1 km/h	3 276,7 km/h
Apparent power [VA]	1 VA	32 767 VA
Voltage [V]	1 V	32 767 V
Current [A]	1 A	32 767 A
Temperature / Temperature difference [K]	0,1 K	3 276,7 K
CO2 Concentration [ppm]	1 ppm	32 767 ppm
Distance / Braking distance [m]	1 m	32 767 m
Distance / Trip distance [km]	0,1 km	3 276,7 km
Amount/Count	1	32 767
Relative value/change as percentage [%]	0,01 %	327,67 %
Torque [m/s ³]	0,1 m/s ³	3 267,7 m/s ³
Time [s]	0,001 s	32,767 s

Table A.2 – Physical quantities (other data types)

Physical quantity [Unit]	Default resolution (unit / bit) 0x1 =	Resulting in a maximum value stored
Time / Date [s]/[1/(2 ³² -1) s]	1/(2 ³² -1) s	The Time data is composed of two unsigned values: The first element is an Unsigned32 data type that provides the time in seconds a) since 1.1.1900, 0:00,00(UTC) for time greater/equal 1.1.1984, 0:00,00 (UTC) and less than or 7.2.2036, 6:28,16(UTC) or b) in seconds since 7.2.2036, 6:28,16(UTC) for time greater or equal 7.2. 2036, 6:28,16(UTC). The second element is an Unsigned32 data type that provides the fractional portion of seconds in 1/2 ³² s).
Time difference [s]/[1/(2 ³² -1) s]	1/(2 ³² -1) s	This data type is composed of an integer value and of an unsigned value that express the difference in time: The first element is an Integer32 data type that provides the time difference in seconds. The second element is an Unsigned32 data type that provides the fractional portion of seconds in 1/2 ³² s.
Position Decimal degrees longitude	Type Float32	Geographical length in degrees (- 180 ... 0 ... + 180) Representation in accordance with DIN EN ISO 6709 Degrees, minutes, seconds and decimal seconds DDMMSS.SS Zeros have to be put in front of degree values if the value is less than 100 and if minutes or seconds are less than 10, zeros have to be inserted at the corresponding positions.
Position Decimal degrees latitude	Type Float32	Geographical breadth in degrees (- 90 ... 0 ... + 90) Representation in accordance with DIN EN ISO 6709 Degrees, minutes, seconds and decimal seconds DDMMSS.SS Zeros have to be put in front of degree values if the value is less than 10 and if minutes or seconds are less than 10, zeros have to be inserted at the corresponding positions.

A.2 Function identification

When identifying functions, the following definitions in Table A.3 and Table A.4 shall be used. The function identifiers orientate on the structure of standard EN 15380-2, which is cited here for information only, because there exists no equivalent IEC standard.

Table A.3 – List of function identifiers (1 of 3)

EN 15380-2	FunctionId	Function	Description, elements
B	–	not applicable	Vehicle body
C	–	not applicable	Vehicle fitting out
DA	'01'H	IntApp	Interior appointments
DC	'03'H	Seats	Seats, Tables
DD	'04'H	SanitaryFac	Sanitary facilities
DF	'06'H	AddDevice	Additional devices
EA	'11'H	RunningGear	Running gear
ED	'14'H	SuspGear	Suspension, damping, balancing gear
EE	'15'H	DrvSystAct	Driving Systems (active)
FA	'21'H	PowerDrive	Power system, drive unit
FB	'22'H	PowerSupply	Power supply
FC	'23'H	PowerGen	Power generation
FD	'24'H	PowerConv	Power conversion
FE	'25'H	PowerDis	Power dissipation
FF	'26'H	PowerStor	Power storage
GA	'31'H	ControlApp	Control apparatus for train operations
GB	'32'H	PowerControl	Power supply controls
GC	'33'H	DrvBrkControl	Driving and brake controls
GD	'34'H	PwrGenCtrl	Power generation control
GE	'35'H	SysDataAcq	System data acquisition
GF	'36'H	PwrStorCtrl	Power storage controls
HA	'41'H	AuxOpEquip	Auxiliary operation equipment
HB	'42'H	ConvEquip	Converter equipment
HC	'43'H	BatteryDev	Battery device
HD	'44'H	OBS	On-board supply system
HE	'45'H	CoolingPwrDrv	Cooling unit for power and drive systems
HF	'46'H	EmergPwr	Emergency power generators

Table A.3 (2 of 3)

15380-2	FunctionId	Function	Description, elements
JA	'51'H	MonitorSafety	Monitoring and safety equipment
JB	'52'H	MeasProtDev	Measuring and protective devices
JC	'53'H	IndicRecDisp	Indicating, recording, display devices
JD	'54'H	SafetyEquip	Safety equipment
JE	'55'H	DataTrans	Data transmission devices
JF	'56'H	CommEquip	Communication equipment
JG	'57'H	MiscEquip	Miscellaneous equipment
JQ	'5F'H	CSOwner	Control System communication
KA	'61'H	Lighting	Lighting
KB	'62'H	ExtLight	Exterior lighting equipment
KC	'63'H	IntLight	Interior lighting equipment
LA	'71'H	AirCondi	Air conditioning
LE	'75'H	ACReg	Regulation
MA	'81'H	AncOpEquip	Ancillary operating equipment
MB	'82'H	Sanding	Sanding equipment
MC	'83'H	Lubrication	Lubrication equipment
MD	'84'H	PointOpDev	Points operating equipment
ME	'85'H	TicketMach	Ticket machines
MF	'86'H	PassCountDev	Passenger counting device
NA	'91'H	DoorsEntr	Doors, entrances
NB	'92'H	ExtDoors	External doors
NC	'93'H	IntDoors	Internal doors
ND	'94'H	EntrSteps	Entrances, steps (not inside)
NE	'95'H	EntrDisable	Entrances for the disabled
PA	'A1'H	InformFac	Information facilities
PB	'A2'H	VisInfoFac	Visual information facilities
PC	'A3'H	VisInfoElem	Visual information elements
PD	'A4'H	Entertainment	Entertainment
PE	'A5'H	Advertising	Advertising
PF	'A6'H	AudiInfoFac	Audible information facilities

Table A.3 (3 of 3)

15380-2	FunctionId	Function	Description, elements
QA	'B1'H	PneuHydrEquip	Pneumatic/hydraulic equipment
QB	'B2'H	PneuGen	Generation
RA	'C1'H	Brake	Brake
RB	'C2'H	BrakeComp	Brake components
RC	'C3'H	MechBFTrans	Mechanical brake force transmission
SA	'D1'H	VehLinkDev	Vehicle linkage devices
SB	'D2'H	ACouplDev	Automatic coupling devices
SG	'D7'H	VVInterface	vehicle-vehicle interface for media, signals, power
TA	'E1'H	CarrierSys	Carrier systems, enclosures
TE	'E5'H	ElectrRack	Electronic rack system
UA	'F1'H	ElectrWiring	Electrical wiring
UK	'FA'H	Common1	
UL	'FB'H	Common2	
UM	'FC'H	Common3	
UN	'FD'H	Internal1	
UP	'FE'H	Internal2	
UQ	'FF'H	InternalETB	

Table A.4 – List of sub-function identifiers and instance info

Function group	Function ID	Sub-function	Function SubId	Instance Class	Instance Class	Remark	
Seats	'03'H	Seats	'0'H			used for vehicle attributes (not for communication)	
SanitaryFac	'04'H	Sanitary facilities	'0'H		0	water/WC	
AddDevice	'06'H	Galley	'0'H		0	galley	
RunningGear	'11'H	RunGearDetect	'0'H		0	running gear supervision	
		RunGearHotBox	'1'H		0	hotbox warning / alarm	
		RunGearDNRA	'2'H		0	detection of non rotating axles	
		RunGearRSM	'3'H		0	running stability monitoring	
		TrackInfo	'4'H		0	hotbox location detection	
		WSS	'5'H		0	wheel speed sensor (blocking) per consist	
		WDiameter	'6'H		0	wheel diameter (axles per consist)	
SuspGear	'14'H	AirSuspEco	'0'H		0	air spring (eco-mode)	
		AirSuspDeflate	'1'H		0	air spring (deflate)	
PowerSupply	'22'H	EnergyCounter	'0'H		0	energy current collector (counter)	
		EnergySystem	'1'H		0	energy collected status	
		EnergyMCB	'2'H			0	main circuit breaker system independent
				AC_outer	1	main circuit breaker AC, exterior section	
				AC_inner	2	main circuit breaker AC, interior section	
				DC	3	main circuit breaker DC	
		EnergyPanto	'3'H	AC_wide	1	wide pantograph AC	
				AC_slim	2	narrow pantograph AC	
				DC	3	pantograph DC	
				DC_shoegear	4	shoegear DC	
		EnergyDcon	'4'H	Trafo	1		
				DCCConnect	2		
				Else	3		
		EnergyExtP	'5'H			0	
				Plug	1		
				Switch	2		
EnergyTransf	'6'H			0			
EnergyAcDc	'7'H			0			
MCBLoopX	'8'H			0			
PowerConv	'24'H	BrakeElectric	'0'H		0		
		TractECounter	'1'H		0		
		TractionStatus	'2'H			0	
				ConvGrp	1		
TractionCtrl	'3'H			0			

Function group	Function ID	Sub-function	Function Subld	Instance Class	Instance Class	Remark	
PowerDis	'25'H	Earthing	'0'H		0		
ControlApp	'31'H	Base	'0'H		0		
		ElectricNet	'1'H		0		
		DiagSysCtrl	'2'H		0		
		TrainConfig	'3'H	TrConf		0	
				Cab		1	
				Data		2	
SysCtrlTest	'F'H		0				
DrvBrkControl	'33'H	HandleCtrl	'1'H		0		
				Tec	1		
				Vsetp	2		
				Dbv	3		
		DrvBrkCtrl	'2'H		0		
		TractCtrl	'3'H		0		
		ASC	'4'H		0		
		Stabling	'5'H		0		
		TractionPower	'6'H		0		
		OMD	'7'H		0		
SysDataAcq	'35'H	CDS	'0'H		0		
		KmCount	'1'H		0		
ConvEquip	'42'H	PowerConv	'0'H		0		
BatteryDev	'43'H	EnergyBattery	'0'H	Battery	1		
				Charger	2		
BatteryEDetect	'1'H		0				
OBS	'44'H	AuxPwrCtrl	'0'H		0		
		BatteryInv	'1'H		0		
CoolingPwrDrv	'45'H	AuxCooling	'0'H		0		
MonitorSafety	'51'H	PassEmergBrake	'0'H		0		
				Control	1		
				Intervention	2		
		State	3				
		EmergCtrl	'1'H		0		
		EBLoop	'2'H		0		
				Control	1		
				Intervention	2		
		State	3				
		PELoop	'3'H		0		
		DoLoop	'4'H		0		
		MCBLoop	'5'H		0		
		EmergLoop	'6'H		0		
RGDLoop	'7'H		0				

Function group	Function ID	Sub-function	Function SubId	Instance Class	Instance Class	Remark
		BrRelLoop	'8'H		0	
		FALoop	'9'H		0	
		LoopCtrl	'A'H		0	
		EBManager	'B'H		0	
MeasProtDev	'52'H	ProtDev	'0'H		0	
IndicRecDisp	'53'H	FireProt	'0'H		0	
				SafeCom	1	
		AudioOutput	'1'H		0	
		HmiEnv	'2'H		0	
		HmiMode	'3'H		0	
		SrVers	'4'H		0	
		SrHMI	'5'H		0	
		SrData	'6'H		0	
				SupvCCU	1	
SafetyNotific	'7'H		0			
SafetyEquip	'54'H	ASD	'0'H		0	
		SafetyATP	'1'H		0	
		JRU	'2'H		0	
		TrainHorn	'3'H		0	
		SafetyEVC	'4'H		0	
		SafetyNVC	'5'H		0	
		SafetyLZB	'6'H		0	
		SafetyDMI	'7'H		0	
		ATO	'8'H		0	
DataTrans	'55'H	MCGStatus	'0'H		0	
				MCG2CCU	1	
				CCU2MCG	2	
		MCGGPS	'1'H		0	
		MCGArchive	'2'H		0	
		MipStatus	'3'H		0	
CommEquip	'56'H	Radio	'0'H		0	
MiscEquip	'57'H	FrontHeating	'0'H		0	
		ScreenWiper	'1'H		0	
		CCTV	'2'H		0	
CCUOwner	'5F'H	MCGStatusQ	'0'H	Dummy	0	
			'0'H	CCU2MCG	2	
		CCU2HMI	'1'H		0	
ExtLight	'62'H	LightSignal	'0'H		0	
		LightExtMode	'1'H		0	
IntLight	'63'H	LightInt	'0'H		0	
AirCondi	'71'H	HvacCompant	'0'H		0	

Function group	Function ID	Sub-function	Function Subld	Instance Class	Instance Class	Remark
		HvacCab	'1'H		0	
		HvacFanComp	'2'H		0	
		HvacFanCab	'3'H		0	
		PressProt	'4'H		0	
Sanding	'82'H	Sanding	'0'H		0	
				WE1	1	
				WE2	2	
		BrakeAirSanddry	'1'H		0	
		SandHeating	'2'H		0	
Lubrication	'83'H	Lubrication	'0'H		0	
DoorsEntr	'91'H	DoorEvac	'0'H	Left	1	
				Right	2	
ExtDoors	'92'H	ExtDoorStat	'0'H	Axle	0	
				Left	1	
				Right	2	
		ExtDoorASDO	'1'H		0	
		IntDoors	'93'H	IntDoorStat	'0'H	Intersect
				Inner	2	
EntrSteps	'94'H	DoorSteps	'0'H	Left	1	
				Right	2	
EntrDisable	'95'H	DoorRamp	'0'H		0	
				Left	1	
				Right	2	
InformFac	'A1'H	PisData	'0'H		0	
		PisCsData	'1'H		0	
VisInfoFac	'A2'H	VisInfo	'0'H		0	
AudiInfoFac	'A6'H	Acustic	'0'H		0	
PneuGen	'B2'H	BrakeAirPress	'0'H	Compressor	0	
				Pressure	1	
		AuxPress	'1'H		0	
Brake	'C1'H	BrakeMode	'0'H		0	
		BrakingPower	'1'H		0	
		BrakeWsp	'2'H		0	
		BrakeBT	'3'H	MbtStatus	1	
				AbtStatus	2	
		PneuBrake	'4'H		0	
				DG	1	
		MgBrake	'5'H		0	
		EddyBrake	'6'H		0	
		ParkBrake	'7'H		0	
DG	1					

Function group	Function ID	Sub-function	Function SubId	Instance Class	Instance Class	Remark
BrakeComp	'C2'H	BrakeDbv	'0'H		0	
ACouplDev	'D2'H	CouplerFairing	'0'H		0	
		CouplStatus	'1'H		0	
		CouplPrep	'2'H		0	
		CouplHeating	'3'H		0	
ElectrRack	'E5'H	DPMaintMess	'0'H		0	
Common1	'FA'H	GlobNonFkt	'0'H		0	
Common3	'FC'H	Commissioning	'0'H		0	
Internal1	'FD'H	IOforCCU1	'0'H			
		CCU1Redund	'1'H		0	
Internal2	'FE'H	IOforCCU2	'0'H			
		CCU2Redund	'1'H		0	
InternalETB	'FF'H	ETB_CCU	'0'H			

Bibliography

ISO/IEC 7498-1, *Information technology – Open Systems Interconnection – Basic Reference Model: The Basic Model*

UIC leaflet 556, *Information transmission in the train (train bus)*, Edition No. 5, August 2009

INTERNATIONAL
ELECTROTECHNICAL
COMMISSION

3, rue de Varembé
PO Box 131
CH-1211 Geneva 20
Switzerland

Tel: + 41 22 919 02 11
Fax: + 41 22 919 03 00
info@iec.ch
www.iec.ch